

erensan^o

a company of / GROUPE
ATLANTIC

HWR



SHW



***liquid/gas fuelled
hot water boilers
(HWR, SHW)
Installation and maintenance
procedure***

erensan^o

a company of  GROUPE
ATLANTIC



ENSURE THAT THE BOILER PERSONNEL
READ THESE OPERATING-MAINTENANCE
INSTRUCTIONS !

***liquid/gas fuelled
hot water boilers
(HWR, SHW)
Installation and maintenance
procedure***

CONTENTS:

FEATURES OF e r e n s a n^o BRAND BOILERS	6
INTRODUCTION	7
<i>BOILER DIMENSIONS FOR DIFFERENT BOILER TYPES. ...</i>	9
BOILER OPERATING PERSONNEL.....	15
TRANSPORTATION AND TEMPORARY STORAGE.....	15
PRESSURING HOT WATER SYSTEM	18
BURNER SELECTION AND INSTALLATION	19
FUEL SELECTION AND STORAGE.....	20
FUEL EQUIPMENT.....	20
Liquid fuel equipment	20
Gas fuel equipment.....	21
SAFETY RULES	22
PREPARATION OF BOILER AND FIRST IGNITION	24
Preliminary Preparations	23
BOILER INSPECTION AND MAINTENANCE RULES	30
General	30
The inspection and maintenance of other outer surfaces	30
Safety valves	30
Inspection and maintenance of inner surfaces	32
Cleaning of inner surfaces	33
Deposits.....	33
Deposits in the shape of crusts	33
Mud.....	33
Corrosion	34
Prevention of corrosion on smoke side	34
CHEMICAL CHARACTERISTICS OF BOILER FEED WATER AND BOILER WATER.....	36
SYSTEM CIRCUIT DRAWING.....	39
BOILER LIFE SPAN	40

FEATURES OF e r e n s a n^o BRAND BOILERS

HWR TYPE HOT WATER BOILERS

- By virtue of pressurized combustion the flame is cycled back in the same cell.
- Gases meeting the flame second time burns the half-burnt fuel particles and convert to heat and polluting waste is annihilated totally.
- The bright flame formed in the combustion chamber by means of the double phase concentrated combustion is passed from the combustion chamber to the water via heat transfer.
- Gas delaying turbulators, increase the speed of the smoke and gases in the flame pipes and enables retaining of convection heat transfer at optimum level.
- Lowers operational costs by quickly getting into the steady state.

SHW TYPE HOT WATER BOILERS

- SHW type hot water boilers includes 3 passes. The heat is transferred into water by radiation in combustion chamber where 1st pass takes place, and by convection and conduction in the smoke pipes where 2nd and 3rd passes take place.
- With the wet back design, the heat transfer surfaces provide maximum benefit.

INTRODUCTION - HWR

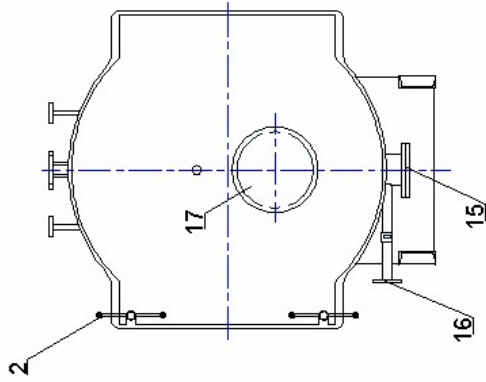

- 1 Flame Inspection System
- 2 Door Handles
- 3 Door
- 4 Lifting Lug
- 5 Safety Nozzle
- 6 Safety Return Nozzle
- 7 Manhole
- 8 Boiler Return Nozzle
- 9 Boiler Nozzle Supply
- 10 Indicator Nozzle
- 11 Safety Valve Nozzle
- 12 Leg
- 13 Smoke Box
- 14 Chimney Duct
- 15 Discharge Nozzle
- 16 Bottom Blowoff Nozzle
- 17 Burner Connection Flange
- 18 Explosion Door
- 19 Cleaning Door

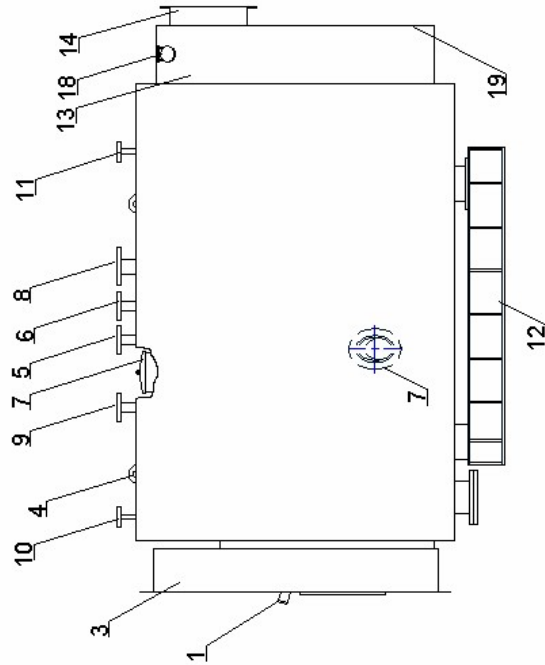

BOILER DIMENSIONS FOR DIFFERENT BOILER TYPES - HWR

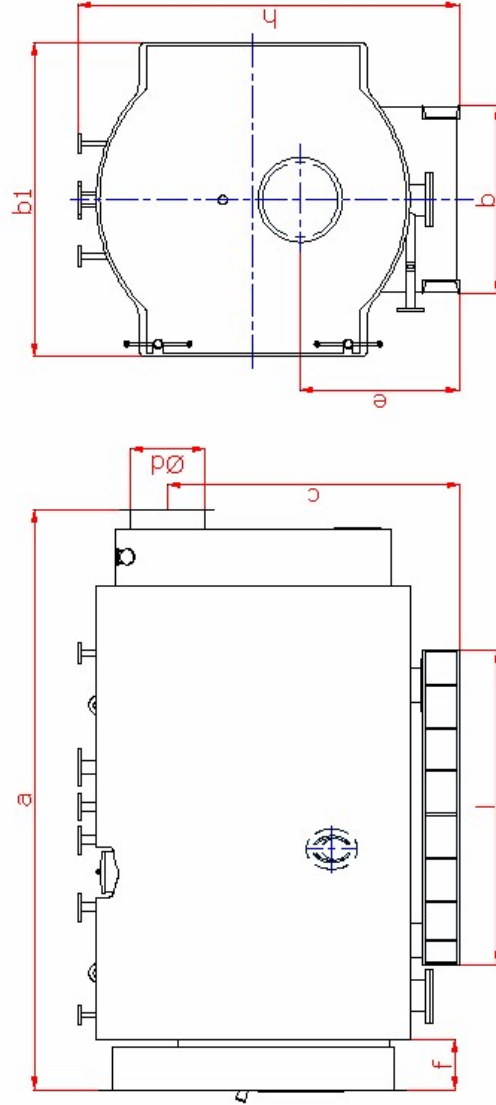

Tip	HWR	400	500	600	750	1000	1250	1500	2000	2500	3500
Kapasite	kcal/h	400,000	500,000	600,000	750,000	1,000,000	1,250,000	1,500,000	2,000,000	2,500,000	3,500,000
Yakıt Miktarı	[kg/h]	45	55	69	86	110	138	172	206	275	378
Yaklaşık Boş Ağırlık	[kg]	1,861	1,861	2,146	2,516	2,881	3,609	4,627	5,430	6,368	8,007
Su Hacmi	lt	1,178	1,178	1,440	1,858	2,246	2,772	3,100	3,464	4,384	6,486
a	[mm]	2,388	2,388	2,573	2,788	2,983	3,350	3,490	3,840	4,115	4,430
b	[mm]	800	800	850	900	960	1,040	1,170	1,190	1,345	1,420
b1	[mm]	1,320	1,320	1,400	1,480	1,550	1,650	1,922	2,000	2,110	2,735
c	[mm]	1,282	1,282	1,332	1,370	1,415	1,530	1,776	1,795	1,898	2,110
Ød	[mm]	300	300	350	400	450	450	500	550	650	750
e	[mm]	743	743	750	771	796	841	948	949	992	1,013
f	[mm]	228	228	228	228	228	270	180	180	180	180
h	[mm]	1,688	1,688	1,751	1,825	1,896	2,016	2,285	2,350	2,481	2,745
l	[mm]	1,314	1,314	1,480	1,780	1,780	2,100	2,000	2,500	2,650	2,700

INTRODUCTION - SHW

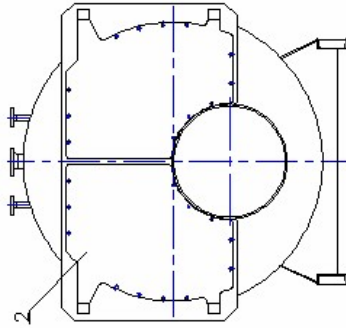

- 1 Flame Inspection System
- 2 Door
- 3 Eyebolt
- 4 Manhole
- 5 Boiler Return Nozzle
- 6 Boiler Outflow Nozzle
- 7 Expansion Outflow Nozzle
- 8 Expansion Return Nozzle
- 9 Safety Valve Nozzle
- 10 Free Filling Nozzle
- 11 Indicator Nozzle
- 12 Stand Group
- 13 Smoke Chest
- 14 Chimney Duct
- 15 Front Smoke Box
- 16 Explosion Flap
- 17 Discharge Nozzle
- 18 Cleaning Flap

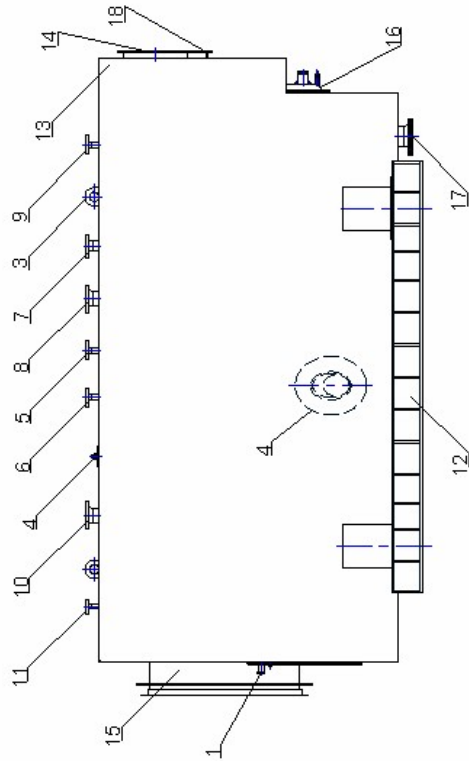

- SHW
BOILER DIMENSIONS FOR DIFFERENT BOILER TYPES

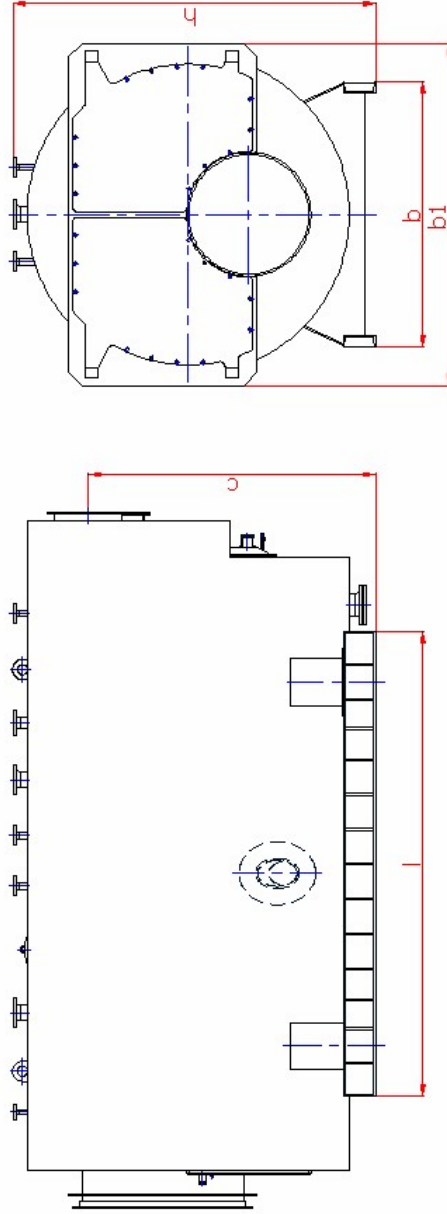

Tip	SHW	0807	1008	1210	1513	1815	2016	2520	3025	3530	4035
Kapasite	[kcal/h]	688,000	860,000	1,032,000	1,290,000	1,548,000	1,720,000	2,150,000	2,580,000	3,010,000	3,440,000
Kapasite	[kw]	800	1,000	1,200	1,500	1,800	2,000	2,500	3,000	3,500	4,000
Gas Miktarı	[Nm ³ /h]	921	1,053	1,331	1,711	1,974	2,106	2,633	3,291	3,949	4,607
Yakıt Miktarı	[kg/h]	71	81	102	132	152	162	203	253	304	354
Duman Tarafı Basıncı Kaybı	mbar	5	6	6	6	6	6	6	6	6	7
Yaklaşık Boş Ağırlık	kg	4,277	4,537	5,304	6,081	7,009	7,403	8,642	10,571	11,647	13,290
Su Hacmi	lt	3,278	3,536	4,596	5,030	6,154	6,124	7,157	8,919	9,720	11,028
a	[mm]	3,936	4,180	4,400	4,460	4,955	4,620	4,935	5,275	5,555	5,810
b	[mm]	1,235	1,450	1,450	1,650	1,750	1,650	1,700	1,900	1,950	2,000
b ₁	[mm]	2,000	2,052	2,130	2,260	2,260	2,300	2,380	2,530	2,575	2,670
c	[mm]	1,599	1,600	1,722	1,780	1,932	1,838	1,903	2,022	2,065	2,128
l	[mm]	2,475	2,610	2,730	2,790	2,880	2,950	3,260	3,460	3,625	3,875
h	[mm]	2,021	2,021	2,154	2,255	2,400	2,400	2,490	2,640	2,690	2,780
Tip	SHW	4540	5045	6050	7060	8070	9080	10090	120100	146120	175146
Kapasite	[kcal/h]	3,870,000	4,300,000	5,160,000	6,020,000	6,880,000	7,740,000	8,600,000	10,320,000	12,556,000	15,050,000
Kapasite	[kw]	4,500	5,000	6,000	7,000	8,000	9,000	10,000	12,000	14,600	17,500
Gas Miktarı	[Nm ³ /h]	5,265	5,923	6,581	7,898	9,214	10,530	11,846	13,237	15,885	19,327
Yakıt Miktarı	[kg/h]	405	456	506	608	708	810	911	1,018	1,222	1,487
Duman Tarafı Basıncı Kaybı	mbar	7	7	8	8	9	9	9	10	10	10
Yaklaşık Boş Ağırlık	kg	14,727	16,252	17,578	19,625	21,515	25,350	26,817	32,086	37,697	44,490
Su Hacmi	lt	13,160	14,257	15,666	16,767	19,729	20,793	22,688	28,901	36,674	41,976
a	[mm]	6,050	6,270	6,740	6,785	7,170	7,515	7,844	8,948	7,450	7,972
b	[mm]	2,040	2,100	2,150	2,280	2,400	2,430	2,465	3,110	3,110	3,500
b ₁	[mm]	2,780	2,840	2,860	2,970	3,110	3,100	3,200	3,670	4,120	4,306
c	[mm]	2,211	2,270	2,282	2,430	2,490	2,550	2,706	3,148	3,300	3,425
l	[mm]	4,120	4,300	4,760	4,755	5,140	5,285	5,615	6,637	5,118	5,635
h	[mm]	2,900	2,980	3,000	3,170	3,290	3,370	3,434	4,092	4,313	4,432
Tip	SHW	-T 232195	-T 175146	-T 146120	-T 1146120	-T 1146120	-T 1146120	-T 1146120	-T 1146120	-T 1146120	-T 1146120
Kapasite	[kcal/h]	20,000,000	20,000,000	20,000,000	20,000,000	20,000,000	20,000,000	20,000,000	20,000,000	20,000,000	20,000,000
Kapasite	[kw]	23,200	23,200	23,200	23,200	23,200	23,200	23,200	23,200	23,200	23,200
Gas Miktarı	[Nm ³ /h]	25,706	25,706	25,706	25,706	25,706	25,706	25,706	25,706	25,706	25,706
Yakıt Miktarı	[kg/h]	1,977	1,977	1,977	1,977	1,977	1,977	1,977	1,977	1,977	1,977
Duman Tarafı Basıncı Kaybı	mbar	10	10	10	10	10	10	10	10	10	10
Yaklaşık Boş Ağırlık	kg	56,921	56,921	56,921	56,921	56,921	56,921	56,921	56,921	56,921	56,921
Su Hacmi	lt	49,473	49,473	49,473	49,473	49,473	49,473	49,473	49,473	49,473	49,473
a	[mm]	8,240	8,240	8,240	8,240	8,240	8,240	8,240	8,240	8,240	8,240
b	[mm]	3,383	3,383	3,383	3,383	3,383	3,383	3,383	3,383	3,383	3,383
b ₁	[mm]	4,670	4,670	4,670	4,670	4,670	4,670	4,670	4,670	4,670	4,670
c	[mm]	3,775	3,775	3,775	3,775	3,775	3,775	3,775	3,775	3,775	3,775
l	[mm]	5,930	5,930	5,930	5,930	5,930	5,930	5,930	5,930	5,930	5,930
h	[mm]	4,830	4,830	4,830	4,830	4,830	4,830	4,830	4,830	4,830	4,830

BOILER OPERATING PERSONNEL

Personnel who will be assigned for the operation of boiler shall be responsible from interfering with any urgent circumstances. For this purpose, the personnel must have concise knowledge of tasks of each device, their characteristics, operational pressure and temperature and flow rates, as well as, tasks and features of all control circuits, measuring devices and electrical safety equipment.

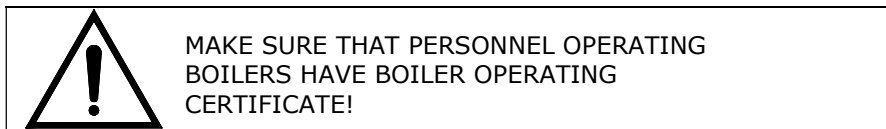

TRANSPORTATION AND TEMPORARY STORAGE

The boiler should be transported using the lifting and transportation points and appropriate equipment.

For horizontal movement; where it is not possible to use a crane, horizontal displacement is possible through controlled sliding movement on pipes.

The boiler should be protected against mechanical blows and collisions during loading, transportation and unloading.

It must be protected against damages resulting from moisture and external mechanical factors that may arise during temporary storage before transportation and installation.

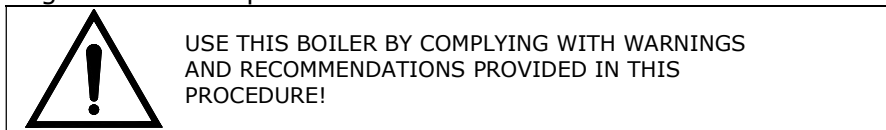

BOILER INSTALLATION

Boiler installation site should comply with the local regulations, related standards and procedures. The door of the boiler room should open towards out-side, and clean air ducts should be placed at the ground level and a contaminated air outlet should be placed at the ceiling level. More than one boiler should not be connected to the same chimney.

Install the boiler on a foundation elevated from the floor in the boiler room at the installation site. A sliding system is installed at the rear feet of the boiler in order to compensate for thermal expansion. Bolts of the sliding system must be kept loose in order for this system to work.

Mechanical connections of boiler should be in conformity with Installation Circuit Drawing.

It is recommended that the hot water boiler should be purchased with armatures as a package. In case the hot water boiler is purchased without its armatures, picking the armatures and setting operating pressure of the boiler should be undertaken in line with related standards and regulations, and assembly should be carried out by expert technical personnel.

Following control equipment shall be placed on the boiler:

- Manometer (min. Ø100mm),
- Pressure switch (2 off them to check upper and lower pressure levels),
- Thermometer (2 off for discharge and return boiler water),
- Temperature control equipment (burner stage number + 1 off)
- Safety valve,

A temperature control system suitable for boiler operating temperature and burner stage should be present.

A full start-up pressure relief valve with boiler opening pressure of * 1,05 bars should be used.

The boiler must be provided with a chimney and smoke channel in compliance with the regulations and standards of the authorized institutions regarding the fuel and smoke gas flow used.

Our boiler is designed as per its label values and therefore, a suitable circulation pump must be used in conformance with these design values and hot water system critical pressure loss.

Condensation water sleeve below the smoke chest should be connected to boiler room discharge line by attaching a hose nipple and a hose to it.

In order to prevent battery corrosion, the boiler must be grounded with,

- a) 0.5m², 2 mm thick copper sheet,
- b) 0.5m², 3 mm thick galvanized sheet (hot dipped)
- c) Solid copper bar electrodes

Automatic locking and protection equipment

In order to secure a safe operating environment, boilers must be equipped with protection locking systems and alarm circuits in line with their capacity and specifications. At least following locking devices should be envisaged in a boiler:

- A system to monitor initial ignition flame continuously and halt the ignition system to prevent forming of main flame in case the ignition flame goes out.
- A photoelectrical monitoring device that will continuously monitor main burner flame and cut the fuel flow when the flame goes out or excessive smoke is produced during burning.
- A pressure switch that will stop the burner in case of excessive system pressure.
- A low pressure switch that stops the burner when the saturation pressure drops below a level that resists operating temperature of hot water system.
- Various switches that keep the pressure within the required limits and controlling flow rates from pressure supplying equipment (nitrogen tubes, steam unit, pressure pump) in the hot water pressuring system.
- A pressure switch to cut the fuel flow in case fuel pump outlet pressure drop in burners that are using diesel as fuel.
- An adjustable temperature switch (thermostat) that will cut off the fuel flow in case fuel temperature drops in burners that are using fuel oil as fuel.
- A pressure switch that shuts off the burner when the boiler burning air pressure drops.
- If an atomization system exists, a device that cut of the fuel flow when atomization pressure (steam or pressured air) drops in liquid fuel burning burners.

- A pressure switch that cuts off the fuel in case of a drop in the gas pressure in gas burning boilers.
- The indicator glasses, control valves, pressure and heat indicators, safety valves, measurement and control devices, locking and protection equipment, air heaters, boiler feeding pumps and blower should be inspected and their maintenance, control and adjustments should be performed.
- Electrical panel, burner panel and burner fan, circulation pumps' vanes should be cleaned with dry pressured air. Should be protected from dust and water.

Other protective elements according to application.

PRESSURING HOT WATER SYSTEM

Hot water system should be kept under pressure at a level that is over the saturation pressure which will resist targeted heat level.

The most common application for pressuring procedure is by using a neutral gas, such as nitrogen over level gauge's container. Pressuring by nitrogen gas reduces the risk of corrosion in the system. The system maintained in desired level of pressure with nitrogen gas cushion over the level gauge container.

Storage tank volume would be considerably large if the level gauge container is sized to hold all expansion water within the system commencing with ambient temperature to operational temperature. Therefore, we recommend that, level gauge container should be sized in conformity with working temperature and it should be design to take the expansion water in a secondary non pressurized storage tank.

Furthermore, there are two methods of creating pressurizing with utilizing steam and pump (high pressure, low flow) When pressurizing by steam, the steam pressure value will be the sum of static pressure of the system, pump pressure, and pressure of expansion of water pressure.

When pressurizing by a pump, the extension tank will be without pressure. Pressurizing is realized by pressure pump. There will be a separate pressure control valve. This valve will keep the pressure within the desired level and will transfer excess water to expansion tank.

PUMPS

Special types of pumps are used in hot water systems. If maximum heat resistance value of the pump is over the desired hot water temperature then pumps may be used directly. Otherwise water cooling pumps must be used. The pumps should not be placed in return circuit.

System pressure values should be checked through the pumps on the outflow and it must be ensured that the pressure level will not exceed limit values for boiler and system.

BURNER SELECTION AND INSTALLATION

To achieve efficient combustion, the burner to be attached to the boiler should be selected in compliance with forming an appropriate flame for the combustion chamber defined in the section referring to boiler technical specifications.

During the installation of a burner, care should be given to match burner nozzle axis with combustion chamber axis.

To prevent entry of excess air into the combustion chamber from outside, the burner installation should be performed carefully to prevent leakage.

The fuel used for operating should comply with burner manufacturer recommendations.

Burner ignition power = Boiler capacity / Boiler yield. Choose an appropriate burner with this capacity that meets the boiler counter pressure. When ordering a boiler, inform the related sales personnel about the burner selected, to ensure that the boiler door and connection flange is designed in compliance with the burner.

The burner barrel tip must enter the burning chamber for a minimum of 50 mm.

Burner operation and safety system must conform to boiler control elements.

FUEL SELECTION AND STORAGE

Fuel complying with the characteristics indicated in the burner user manual or burner vendor catalogues should be obtained.

Fuel transfer lines should conform to current technical specifications, regulations and standards. The fuel tank-burner axis levels should not exceed figures specified in the burner user manual.

Fuel tanks should conform to standards. A wall must exist between the fuel tank and the boiler.

If fuel-oil is being used (especially of a heavier group), the necessary arrangements (RING LINE) and heating installation should be prepared for flow of fuel from the tank to the burner.

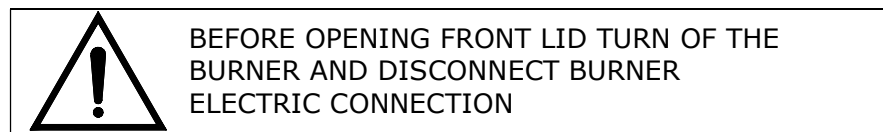

FUEL EQUIPMENT

Fuel equipment is comparatively important in the management of hot water boilers. Various burning equipment exist for diverse fuels.

Regardless of fuel type to be used, fuel equipment should be inspected before ignition.

A pre-sweeping duration as defined in burner's memory for the purpose of ventilating and discharging possible accumulation of flammable gas mixtures in the burner and chimney gas channels should take place for discharging such gases after initial ignition of the boiler or re-igniting a burner that has stopped for any reason.

Liquid fuel equipment

In liquid fuel burning boilers, all tanks, heaters, pumps, valves and piping system of the fuel circuit should be checked and ensured that they are in good condition and operating normally.

In case the liquid fuel tank is located in a lower position than fuel pumps, the valves, flange filter and other parts should be inspected and full leak tightness should be ensured hence sucking of air by the pump should be prevented. In case fuel oil is used as a liquid fuel, all heaters that are working with electricity and steam should be checked for proper working condition. A leakage of fuel

oil to the steam section should be checked in steam heaters. In order to detect this, oil pump should be started, and maximum pressure of system should be applied for five minutes duration by using the first valve after pump safety valve or the first valve after heater outflow on the fuel oil pipe. After this procedure, the steam inlet should be opened all the way and condensation water should be checked for fuel oil.

The most important cause for irregular burning in liquid fuel burning boilers is that full atomization is not attained. In order to attain full atomization, application of atomization recommended by the burner producer is necessary.

Water that is settled at the bottom of the liquid fuel tank should be discharged.

Fuel pump should be operated and fuel circulation should commence after ensuring viscosity of fuel oil in the pipes. All grease fuel equipment should be de-aerated.

The fuel waste that is accumulated in the burner, in front of the boiler and especially at the base of the furnace should be cleaned before ignition.

Gas fuel equipment

The valves and flanges on the gas pipe and all joints should be checked for gas leakage; all burning equipment, burner, safety valves and similar equipment should be inspected and any leakage should immediately be stopped on the gas fuel system prior to ignition.

Burner should be ignited only after adjusting gas and air quantities to initial ignition values.

During the burning process, the fuel valve/s that is/are placed right after the last manometer in front of the burner group should be kept open all the time in burners where both gas and liquid fuel is used. Otherwise, the real conditions within the burner (such as actual value of fuel pressure given to burner) will not be monitored.

SAFETY RULES

- Use the boiler only for the purpose of hot water production for the closed circuit heating system.
- The boiler should be used in compliance with warnings and recommendations presented within this procedure.
- Hot water system should be installed by authorized personnel.
- Boiler electrical connections should be installed by authorized personnel.
- In case water level and pressure is below projected values, the boiler should not be operated.
- When opening the front door, shut off the burner and shut down burner electricity.
- Make sure that the boiler personnel are certified boiler operators.
- The boiler chimney should be built in compliance with chimney building rules. Airbrick and briquette should not be used in boiler chimneys.
- Chimney cleaning should be undertaken twice a year and it should be ensured that the chimney does not have any cracks or holes, and the chimney cleaning door is closed and insulated properly.
- It must be ensured that, the water level and pressures of boiler expansion tank and hot water system are within envisaged limits and circulation pump's suction and forcing valves are open, system air is de-aerated and pump circulation direction is correct during initial ignition and consecutive ignitions.
- In case abnormal noises are heard from boiler or installation, the burner should be stopped immediately. The fault should be determined and eliminated after turning off the system.
- The temperature of the feed water that complements hot water system's decreasing water levels should not be below 80°C. Heating should be obtained through coil system and controlled thermostatic valve. Furthermore, water level of the tanks should be monitored by water level feeding device or any other level control apparatus. When the water level decreases, the solenoid valve should be opened to enable soft water flow and the solenoid valve should be closed when the desired water level is attained.
- In case burner is not working do not press reset button of the control unit more than twice and call the burner service line.

- If leakages are observed on the burner fuel attachments and transfer lines, the burner should be immediately stopped and line valves should be closed. If natural gas or LPG is used, use a leakage detector device in the boiler room and an automatic fuel cut-off system on the main inlet.
- If LPG is used, when icing and dew is observed on the fuel pipes due to the liquidizing of residual gas in fuel pipes from the previous night especially on cold days, the burner should absolutely not be used. The liquid LPG should be carefully discharged from the drain tap. (Liquidizing may also form at normal times due to gasification level control or line regulator problem.)
- In cold climate environments, necessary measures should be taken to prevent installation water temperature falling below freezing temperature. If heating is to be ceased for a long period of time, the boiler and system water should be discharged. Antifreeze should not be used. (Antifreeze causes corrosion and a decrease in water thermal transmission capacity.)
- The boiler door should absolutely not be opened before stopping the boiler and disconnecting electricity.

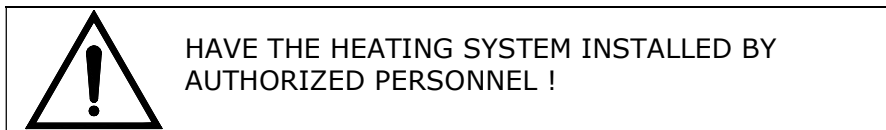

PREPARATION OF BOILER AND FIRST IGNITION

Preliminary Preparations

A boiler that will be commissioned for the first time or after completing maintenance and repair on it, should be inspected thoroughly on its water and gas systems (inside the furnace, chimney gas outlets, air heaters, boiler cells, etc), any tool, pieces of cloth, iron bars, fillers, etc. should be removed. Dust, oil-carbon deposits, cinder and similar waste should be cleaned of by washing or sweeping.

Interior parts of the boiler and all other brackets, straps and similar parts should be tightened if they are loose. After completing this process, all openings should be closed and manholes should be tightened by using appropriate sealants.

Make sure that all equipment within burning assembly and chimney draft system are in proper working condition and all flaps, if they exist, are opening and closing easily. It must be ensured that all mechanical and electrical connections of burner and fuel line are connected, all systems are adjusted, tested and calibrated and the system, as a whole, is in a flawless working condition.

Mechanical and electrical connections of all armatures in the hot water system (boiler, expansion tank, feeding water tank, feeding water pumps, circulation pumps) should be checked for proper assembly.

The nuts on the boiler feet should be loosened and bolts should be freed.

Filling the system with water

Water softener equipment's inlet and outlet valves are opened and the equipment is commissioned as per the instructions provided.

Feeding water tank inlet valve is opened. After filling feeding water tank with water a bit, tank discharge valve is opened to discharge dirty water.

Boiler inlet and outlet valves, expansion tank air vent hole and connection valves are opened. Feeding water pump is started and a small amount of water is let into the boiler and flushed from the boiler.

The nitrogen connection valve on the expansion tank should be kept closed while filling the water.

When filling up with water, water feeding tank level and functionality of level control elements should be checked.

Circulation pumps and valves of the lines where the water will be provided shall be opened while continuing with water filling application. Simultaneously, air is taken out from air vents located over the lines.

Circulation pumps will be run for a while after the system is filled with water. After they are shut down, air is vented again and strainers placed at the suction circuits of the pumps are cleaned.

Feeding water pumps are restarted and water is filled until determined static pressure is obtained.

Finally, the air is vented out again while paying attention for not leaving any air within the system.

Filling nitrogen into the system

Nitrogen tubes should be kept full at all times. Regulator is adjusted (to lower pressure setting). The solenoid valve that lets nitrogen into the system is located on nitrogen collector. The solenoid valve is controlled through low pressure switch placed on the expansion tank. When pressure drops, solenoid valve opens with the signal received from low pressure switch and nitrogen is fed into expansion tank. When desired pressure is attained, a signal originating from pressure switch will shut off the valve and feeding of nitrogen will be stopped. The valves in front and behind the solenoid valve should be in open position, and the by-pass valve should in closed position. The intermediary valves of pressure switches should always be open. When solenoid valves malfunction and needed to be changed, replacement valves should be identical to the originals in diameter, electrical values and working parameters.

Nitrogen is used for keeping the pressure in required level. When nitrogen system malfunctions or any leakage of nitrogen or water, sudden pressure drops will be observed. It is dangerous to go below necessary pressure level for system heat. In such circumstances, the valves of the circuit where the leakage occurs should be turned off rapidly and at the same time additional water should be pumped into the system in order to increase pressure levels.

SYSTEM CHECKS

EXPANSION TANK

- **Lower water level control**

The feeding pump will start to work when the water level falls lower level control axis. If water level will continue to drop, the control element shall stop boiler and initiate an alarm. It will stop feeding pump when water level becomes to normal.

- **Upper water level control**

Expansion tank flooding motorized valve will be opened if water level is above normal. If water level will continue to rise, it shall stop boiler and initiate an alarm. Motorized flooding valve shall be shut off when the water level becomes normal.

- **Pressure control**

In case of pressure increase within the tank (nitrogen side) its stops the burner and initiates an alarm. Discharge of nitrogen is

executed. Nitrogen feeding will be carried out by opening solenoid vents of nitrogen circuit in case pressure drops. If it continues to drop it will stop the burner.

BOILER

- A device should be placed in the system to prevent operating without water (a switch or a electrode) and its functionality should be checked.
- Temperature control elements should be placed in the boiler (thermostat, etc.) and it should stop the burner when pre-set maximum temperatures are reached. In addition to this, a secondary safety temperature control element that is set 1-2°C above maximum temperature control element.
- In case of malfunction of pressure switches of the boiler and system a mechanical fully operational safety vent should be installed for protection of boiler.
- Maximum and minimum value pressure switches placed on the boiler keep the pressure level in required values. Before pressure reaches lower danger level, minimum pressure switch, and before pressure reaches upper danger level maximum pressure switch will stop the boiler.

FEED WATER TANK

- **Temperature control**

The temperature of feed water should not be lower than 80°C and over 100°C. Heating can be realized by a coil system. Water temperature may be determined by a thermostatic valve at the entry point of the coils. Controlling maximum water temperature in the tank; it may be possible to check by a safety flush or safety vent by utilizing water's own steam pressure (0,2-0,4 bar).

- **Level control**

It can be achieved by a feeding measuring device or any other level control apparatus. When the level drops, it opens the solenoid valve at the soft water entry point and closes when the level reaches to normal.

SYSTEM

- It must be observed that working valves are in open position.
- De-aeration must be carried out at places where air is likely to be accumulated (air relief cock, vent hole).

- The differences between system intake and outlet temperatures are predetermined in conformity with the project. The boiler design should be suitable for the same temperature difference. In case the return temperature is below predetermined level, the temperature difference should be aligned by trimming by-pass valve located between the collectors.
- Different level of pressure may be obtained in various parts of the system due to circulation pump. These pressure values should continuously be monitored and must be stabilized. Temperatures should be read and checked locally.

COMMISSIONING

- Check system and boiler connections.
- Boiler intake and outlet valves should be in open position.
- Valves located in front and behind the solenoid valves should be in open position.
- Nitrogen tubes should be checked for their fullness and it should be observed that gas feeding valves are open.
- The valves of circulation pumps that will be operating should be in open position and cooling water circuits, if exists, should be opened.
- It must be observed that feeding pumps' valves are in open position and are in working condition.
- The direction of the pumps must be checked and if any reverse turning is observed, it should be corrected.
- Minimum pressure, pressure switch should be adjusted to zero (0) in initial start-up and should be adjusted to required level afterwards.
- It must be observed that fuel circuit is ready for the operation. In case fuel oil is used for fuel, temperature of the fuel must be checked.
- It must be observed that static pressure of the water is the same within the system prior to operation of the pumps. (except difference of height)

- It must be checked that water in the extension tank is in normal level.
- The feeding water tank must be full.

OPERATION

- First of all, hot water circulation pumps will be turned on and flow control element's function is to be checked.
- Re-circulation pumps, if exists, will be turned on.
- System air shall be checked and de-aerated.
- Pressure should be checked continuously while system water temperature rises slowly.
- Before obtaining desired hot water temperature, IT MUST BE CHECKED THAT THE SYSTEM PRESSURE IS NOT BELOW RESISTING SATURATION PRESSURE OF HOT WATER TEMPERATURE.
- System will be de-aerated when the water temperature reaches desired level.
- Depending on boiler's expected operational temperature difference, trimming of circulation pumps should be carried out to stabilize inlet and outlet water temperatures.
- In case of starting off a closed circuit for any reason, valve of the circuit should be opened slowly to let the circuit warm up gradually. After warming up, valve should be moved to open position. At the same time, pressure of the system should be checked and water must pumped in immediately if in case pressure drops.
- In case there are more than one boiler in the system and if one of them is not working, its valves should be in closed position. In case starting of a boiler, water to be pumped in the boiler should not be more than 60°C.
- It must be checked that the control devices are enable to halt burner's operation at required values. Boiler's minimum pressure switch should be reset.

If the system is to be halted for a extensive period of time, the burner should be stopped first and circulation pumps must be turned off later.

PERFORM THE INSPECTION AND
MAINTENANCE ACTIVITIES OF THE
BOILER THOROUGHLY!



BOILER INSPECTION AND MAINTENANCE RULES

General

Periodical maintenance of hot water boiler should be scheduled in consideration of operation and contamination conditions. Under normal operating conditions, smoke section (burning chamber, smoke pipes and smoke chest) cleaning and maintenance chores should be carried out every two weeks and every two months for liquid and gas fuels respectively. Water sections should be cleaned and maintenance work should be carried out every six months. Due to operational conditions of boiler, shorter periods should be considered if contamination levels are high.

Hot water boilers should be stopped at least once a year and a general inspection and maintenance work should be carried out on boiler equipment.

The following points should be checked during general maintenance.

The inspection and maintenance of other outer surfaces

- The boiler must be inspected from outer side and should be checked for tearing, breaking and opening in welding points due to expansion.
- The turbulators should be taken out and all pipes should be cleaned with a suitable mop. Turbulators should be reinstalled in their place after cleaning. For full boiler efficiency, turbulators should be installed in full.
- All leakage and escape points determined should be sealed. Excessive force should not be applied during tightening. If leakage continuous after tightening, the related part must be disassembled and surfaces should be cleaned and new gaskets should be inserted. While taking of gaskets from shiny surfaces, care must be administered for not scratching such surfaces.

- All valves, pipes, pipe fittings and external pipes on the boiler and boiler system should be inspected against leakage.
- The operation of boiler armatures (heat control elements, thermometer, manometer, pressure switches, flow control devices, safety flaps) should be observed continuously and in case of a malfunction, necessary checks should be undertaken and if needed, they should be changed. Heat transfer should be improved by filling the thermometer cartridges with thin lubricant.
- Sealants of boiler lid and smoke chest should be checked, and in case of a leakage, tightening elements should be tightened in a balanced manner. If the leakage is not constrained gasket/sealant should be changed or our authorized services should be contacted. Grease the bolt screws and nuts of tightening elements.
- Manholes that are determined as source of leakage must be maintained and leakages should be constrained.
- In case the chimney is situated right over the boiler or boiler construction, precautions taken for stopping rain water's entry into the boiler and hence causing corrosion should be checked.
- Steel constructions, platforms and stair cases, boiler surface pipes, support carriers, pipe brackets should be checked for loosing or bending.
- The boiler and system water should not be discharged if it is not necessary. During prolonged stops, appropriate chemical protective additive should be added to system water, to prevent negative effects of the oxygen and similar corrosive elements in water on the metal surfaces. Boiler that will be out of operation for an extensive period of time, boiler heating metallic surfaces should be protected against oxidation by applying transformer oil or a thin metallic lubricant.
- Temperature gages should be compared to a calibrated thermometer.

- The boiler and its surrounding area, air ducts, chimney base, burners, in front of the boiler, fuel system and control devices should be kept clean at all times. The tools and handsets that will be used during maintenance should not be thrown around.

Safety valves

Usually there are two safety valves over the hot water boiler.

The safety valves should be in good working conditions at all times.

Safety valves should be hot tested at least once a year to ensure that their opening and closing values are in conformity with their given label values.

Without taking into consideration of the adjustment of the safety valves by their respective manufacturer, the values given on labels must be checked.

In case a leakage is determined during the operation on safety valves, the safety valve should be opened manually for repair purposes, and let hot water to be discharge and flush the foreign materials on the facing surface of the valve. If the leakage is not prevented after this remedial work, safety valve should be disassembled and repaired after cooling down the boiler. The spring pressure should not be increased in order to eliminate the leakage in safety valves.

The following formula must be taken into consideration when opening a safety valve:

$$P_{\text{open}} = 1,05 \times P_{\text{operation}}$$

EXAMPLE: Safety valve adjustment pressure for **6 bar** operational pressure:

$$P_{\text{open}} = 1,05 \times 6 = \mathbf{6,3 \text{ bar}}$$
 is derived.

Inspection and maintenance of inner surfaces

- The pressurized inner surface of a boiler is inspected for the purpose of suitability of feeding and boiler waters' chemical properties. For this purpose, the boiler doors must be open and boiler must be well ventilated before going inside.
- The portable lamps and their apparatus that will be used in the boiler for illumination purposes should be less than 42 Volts and extension cables should be flawless and should have heavy insulations. Places where the cables could be damaged (sharp edges, edges of lids, etc.) should be protected to prevent cuts and crushing and all electrical appliances should be grounded properly and equipment with lowest possible voltage value must be selected. All electrical connections must be performed outside the boiler.
- The inner sections of pipes in flame piped boilers must be inspected by a light and it must be ensured that they are clean and not clogged.
- During washing and mechanical cleaning of pipes, care should be given in order not to damage the pipes.

Cleaning of inner surfaces

- After assembly of a boiler, it should be clean thoroughly before commissioning, and it should be free of rust, any material that cause corrosion, waste grease, organic material wastes, and remnants of protective paint, welding electrodes, construction and assembly parts.
- The surfaces that will be in touch with water should be cleaned off from materials such as oil, grease, fatty acids, rust, paints.
- It is necessary to obtain professional services of expert companies of chemical boiler cleaning.
- In case the boiler will be kept out of operation for a while, regular weekly cleaning should be carried out and surfaces

should be wiped with carbonate dilution to remove acidity. In case there is an accumulated layer, cleaning with carbonate dilution should be carried out as necessary. Sufficiency of sulphur cleaning may be checked with a pH paper (pH value must be between 7 and 9). Removing acidity should be undertaken when the boiler is between 50 to 60°C. When this procedure is complete, the surfaces are left alone for drying and later, linseed oil, turpentine and graphite are sprayed on the surface for protection from rust. Boiler doors must be shut to prevent air circulation. Furthermore a cup of semi burnt lime should be placed inside the boiler for withdrawing humidity.

Deposits

The solid material deposits in the boiler are in the shape of crust and mud pilings in pipes, etc.

Deposits in the shape of crusts

The reason for crusting is that the chemical environment similar to that of boiler water does not exist to turn the deposit into mud and hence such deposits will be hardened and stack to surfaces instead of becoming mud piles.

Crusting will result in excessive heating on crusted surfaces and in return it will result in pipe punctures. In order to prevent crusting, boiler feeding water should be treated in a manner to possess required chemical conditions before forwarding into the boiler. Water in the boiler must also be kept in suitable chemical condition. The verification of applied chemical process must be carried out by analyzing boiler feeder water.

Mud

Having mud on the surface of boiler is an important situation since accumulation of mud will decrease thermal transfer and hence the surfaces will be heated up excessively.

When the boiler is put out of service, the water inside the boiler should not be discharged until it gets cooler so that the mud will not be hardened by the heat of the boiler.

Corrosion

Corrosion may happen while the boiler in operation or when it is inactive. If there is no crust shape deposits in the boiler, the life expectancy of boiler's metal parts and pipes depend on regional pitting or abrasion due to corrosion.

If there are red or black iron oxide stains in pitting areas, it is the cause of boiler water having neutral or alkaline characteristics of the boiler water.

The boiler water that is in contact with metal parts, create pitting when alkaline compounds are intensified in a section where excessive heat is present and no sufficient water circulation exists. Similarly, corrosion takes place in waters with neutral characteristics in a prolonged period of time. As a result of this type of corrosion, iron oxide and hydrogen gases evolve.

Sometimes, on surfaces that are covered with deposits, due to high metal temperatures caused by poor thermal transfer, the materials that make up the deposits reacts with the metal and as a result corrosion occurs.

Prevention of corrosion on smoke side

When liquid fuel and especially heavy grade fuel oil is used as a fuel, 3% of sulphur is contained in the fuel. Sulphur is accumulated in secluded places during burning process on the boiler burning and smoke sections. During the stoppage and restart of the boiler, as a result of condensation of steam within the chimney gases, condensed water joins sulphur molecules to form sulfuric acid.

In order to prevent this;

- Liquid fuel with low sulphur content should be used.
- Soot and smut gathering on the heating surfaces (combustion chamber, smoke pipes, smoke chest) should not be allowed, and cleaning process should be performed as frequently as possible.

- Panorin must be applied to boiler heating surfaces (smut on the surfaces will disappear and cleaning process of boiler smoke section will become easier).
- Burner should not be stopped too frequently.
- Burner burning adjustment should be correctly made. Burner adjustments should be undertaken by authorized services by using a Chimney Gas Analyzer.

CHEMICAL CHARACTERISTICS OF BOILER FEED WATER AND BOILER WATER

Water that will be used in hot water boilers should be treated. The required chemical properties of treated feeding water and boiler water are presented in the tables and graphics provided herein below. The boiler feed water and boiler water should be checked constantly and the chemical conditions required for the water should be ensured in order to operate the boiler efficiently and economically.

FEEDING WATER FOR HOT WATER BOILERS [OPERATIONAL PRESSURE IS BETWEEN 0,5 AND 20 BARS]

Parameters	Unit	Conductivity of feeding water	
		> 30 μS/cm	≤ 30 μS/cm
Operating Pressure	bar	> 0,5 to 20	
	MPa	> 0.05 to 2	
Appearance	clean, no suspended particles	-	
Conductivity at 25 °C	μS/cm	< 8000 ¹⁾	μS/cm
At 25 °C pH value ¹⁾	-	> 9,2 ²⁾	
Total hardness (Ca Mg)	mg/liter (ppm)	< 2 [= 0.2 Fr.H ³⁾	
Iron (Fe)	mg/liter (ppm)	< 0,3	mg/liter (ppm)
Copper (Cu)	mg/liter (ppm)	< 0,05	mg/liter (ppm)
Silicate (SiO ₂)	mg/liter (ppm)	80	mg/liter (ppm)
	mg/liter (ppm)	107	mg/liter (ppm)
	mg/liter (ppm)	133	mg/liter (ppm)
	mg/liter (ppm)	160	mg/liter (ppm)
Oxygen (O ₂)	mg/liter (ppm)	< 0,05 ⁴⁾	mg/liter (ppm)
Oil/grease	mg/liter (ppm)	< 1	mg/liter (ppm)
Organic materials	-	5. see paragraph	

¹⁾ pH value should be kept between the range of 8.7 – 9.2 in copper alloy system.

²⁾ While considering pH value given in the boiler water specifications table below, pH value of soft water should be kept at >7,0. (refer to table given below).

³⁾ For working pressure of <0,5 Mpa (5,0 bar), total hardness of max. 0,05 mmol/liter (5 ppm=0,5 FrH) may be accepted.

⁴⁾ It is restricted with continues operation and/or use of economizer. Under disrupted working or working without degasified working conditions, excessive film forming and/or oxygen suppressant chemicals should be observed.

BOILER WATER FOR HOT WATER BOILERS [OPERATIONAL PRESSURE IS BETWEEN 0,5 AND 20 BARS]

Parameters	Unit	Conductivity of feeding water > 30 $\mu\text{S/cm}$	Conductivity of feeding water $\leq 30 \mu\text{S/cm}$
Operating Pressure	bar	< 0,5 to 20	> 0,5
	MPa	< 0.05 to 2	> 0,05
Appearance	-	clean, lasting, no foam	
Conductivity at 25 °C	$\mu\text{S/cm}$	< 8000 ¹⁾	< 1500
pH value at 25 °C	-	10,5 to 12,0	10,0 to 11,0 ²⁾ ³⁾
Acid capacity up to pH 8.2	mmol/liter	1 to 15 ¹⁾	0.1 to 1.0 ³⁾
Silicate (SiO ₂)	Acid capacity up to 0,5 mmol/lit, pH 8.2	mg/liter(ppm)	80
	Acid capacity up to 5 mmol/lit, pH 8.2	mg/liter(ppm)	107
	Acid capacity up to 10 mmol/lit, pH 8.2	mg/liter(ppm)	133
	Acid capacity up to 15 mmol/lit, pH 8.2	mg/liter(ppm)	160
Phosphate (PO ₄) ³⁾	mg/liter(ppm)	< 30	< 15
Organic materials	-	5. see paragraph	

¹⁾ If there is a superheater, take 50% of this value as a maximum value.
²⁾ It is the base adjustment of pH with Na₂PO₄ injection. In case the pH value is <10 ten only NaOH injection will be made.
³⁾ If the acid conductivity of boiler feed water is <0,2 $\mu\text{S/cm}$, and Na + K concentration is <0,010 mg/liter then phosphate injection is not necessary. Alternatively, if the feed water pH $\geq 9,2$ and boiler water pH $\geq 8,0$ then all volatile compounds may be used for the process, however in that case the boiler water's acid conductivity must be < 5 $\mu\text{S/cm}$.
⁴⁾ If there is a non-iron material such as Aluminum in the system, low pH and conductivity may be necessary, in all cases protection of the boiler should be a priority.
⁵⁾ If phosphate is used for balanced or coordinated phosphatization process, higher PO₄ concentrations may be acceptable by considering all other values. 4. please refer to the paragraph

Ref : prEN 12953-10, Table 5-1, 5-2; 1998

SYSTEM CIRCUIT DRAWING

A hot water system layout is provided as an example. A system should be designed taking into consideration of operational needs and specifications of the process where hot water is used.

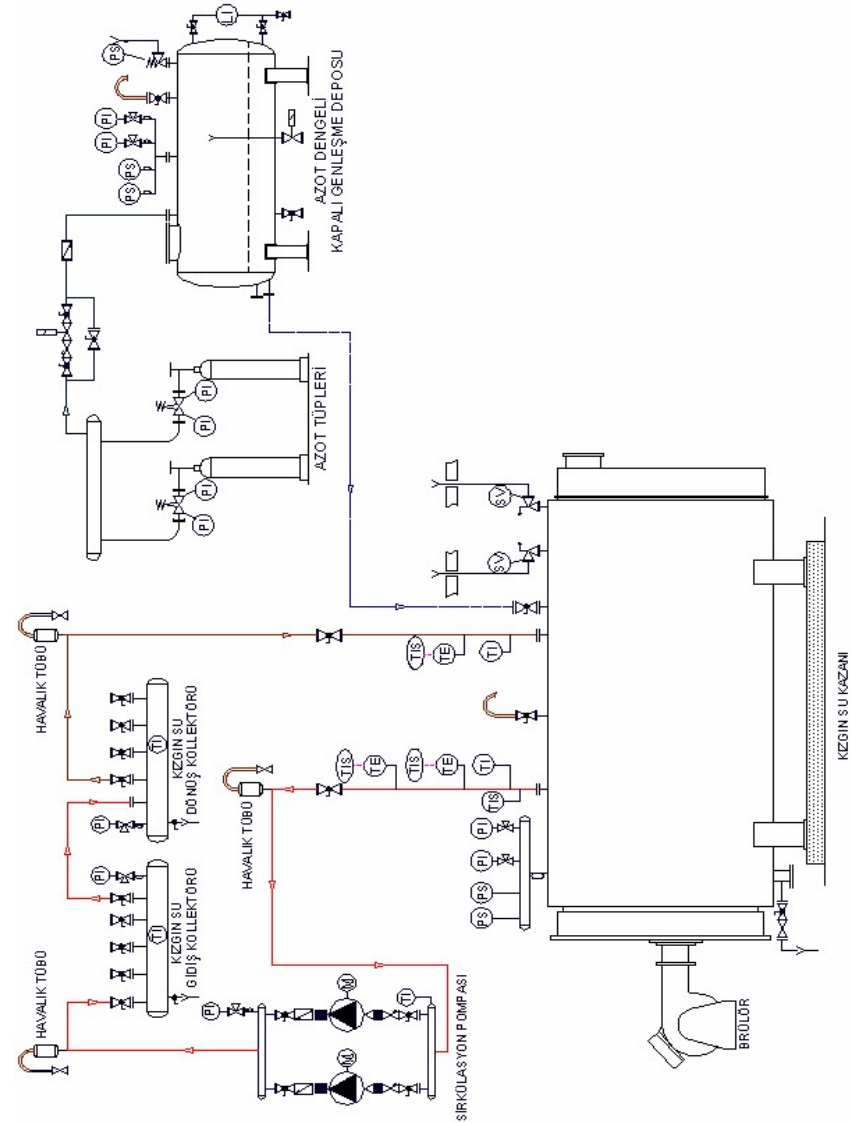

System circuit diagram

PS	Pressure Switch
PI	Manometer
SV	Safety Valve
LI	Water Level Indicator
LS	Feeding Measurement Device
LE	Level Electrode
K	Water coming from condensation tank
TI	Thermometer
M	Engine
P	Pump

erensan° Istanbul Headquarter

Yassiören Mah. Balkırı Sk No:16-22

Arnavutköy İSTANBUL

Tel: 0212 551 05 00 pbx Fax: 0212 551 34 84

e-mail: info@erensan.com.tr

erensan ürünleri + riello brülör+ unigas brülör

erensan° Ankara Region

Öveçler Mah. 1314 sk. 41/B Çankaya / ANKARA

Tel: 0312 427 67 37/3 hat Fax : 0312 428 48 72

e-mail: ankara.bolge@erensan.com.tr

erensan ürünleri + riello brülör+ unigas brülör

BOILER LIFE SPAN

If **erensan°** brand boilers are utilized in compliance with operating and maintenance instructions, it is possible to go well over the ministry stated life span. Therefore, **make sure that this operating and maintenance procedure is read and fully applied by operating personnel.**

When the boiler has reached unusable state, remove the scraps from usage area in compliance with environmental procedures.

HOPE YOU ENJOY USING YOUR BOILER.....

erensan^o

a company of  GROUPE
ATLANTIC

ERENSAN ISI CİH. PAZ. VE SERVİS A.Ş.

Yassiören Mah. Balkırı Sk No:16-22

Arnavutköy -İSTANBUL

Phone: 0212 551 05 00 Fax: 0212 551 34 84

ERENSAN ISI CİH. PAZ. VE SERVİS A.Ş.

Öveçler Mah. 1314 sk. 41/B Çankaya-ANKARA

Phone: 0312 427 67 37 Fax: 0312 428 48 72

ERENSAN ISI TEKNİĞİ SAN. VE TİC. A.Ş.

Organize Sanayi Bölgesi, 107 Ada, 1-2-3 Parsel

66900 Yerköy-YOZGAT

Phone: 0354 558 11 20 Fax: 0354 558 11 23

<http://www.erensan.com.tr> e-mail: info@erensan.com.tr

İB52007-1

Our company reserves the right to make amendments without prior notification.