

erensan^o

a company of  GROUPE
ATLANTIC



***liquid/gas fuelled
TRIPLETTE (TR)
central heating boiler
operating, maintenance and
instruction manual***

erensan^o

a company of  GROUPE
ATLANTIC

***liquid/gas fuelled
TRIPLETTE (TR)
central heating boiler
operating, maintenance
and instruction manual***



ENSURE THAT THE BOILER PERSONNEL READ THESE
OPERATING-MAINTENANCE INSTRUCTION !

CONTENTS

o Properties of liquid/gas fuelled boilers.....	6
o Manufacturing and testing standards applied.....	6
o Introduction.....	7
o Boiler dimensions.....	9
o Boiler operating personnel.....	10
o Transportation and temporary storage.....	10
o Boiler installation.....	11
o Expansion tank and safety pipes.....	12
o Burner selection and installation.....	17
o Combustion chamber dimensions.....	18
o Fuel selection and storage	19
o Filling the system with water.....	19
o Preparation of the boiler for operation.....	20
o Safety rules.....	21
o Putting boiler in operating.....	23
o Heating system adjustments.....	25
o Discharging the boiler water.....	26
o Taking boiler out operation.....	26
o Prevention of low temperature corrosion.....	27
o Inspection and maintenance of boiler.....	28
o General maintenance.....	28
o Hydrostatic test.....	29
o General boiler malfunctions.....	30
o Boiler control panel installation	32
o Control panel dimensions.....	34
o Boiler control panel electrical schema.....	35
o Installation circuit diagram.....	37
o Boiler feed water and boiler water chemical characteristics	38
o Boiler life span.....	39
o Authorized services.....	40

FEATURES OF erensan° BRAND BOILERS

- TRIPLETTE type hot water boilers have triple pass. Radiation from the combustion chamber where the 1st passages is formed, convection from the smoke pipes where the 2nd and the 3rd passages are formed and the conduction are carried to the water with heat transfer.
- With the wet back design the heat transfer surfaces provide maximum benefit.
- Gas accelerating turbulators, increase the speed of the smoke and gases in the flame tubes and enable convection maintenance of heat transfer at optimal level.
- erensan° brand liquid and gas fuelled hot water boilers, which provide high efficiency with these features, lower operational costs by quickly getting into the steady state.

STANDARDS APPLIED TO MANUFACTURING AND TESTING

BOILERS BETWEEN TR 80 – TR 1000

TS EN 303-1
TS EN 303-2
TS EN 303-3
TS EN 304

TR 1250 TYPE BOILER

TS 497
TS 4040
TS 4041

INTRODUCTION

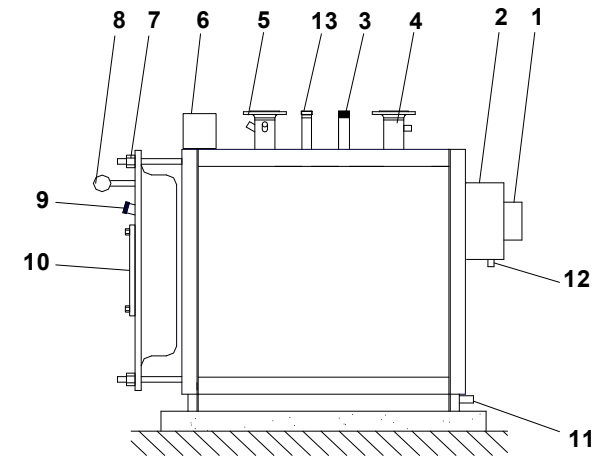

TR 80-350

1. Chimney duct
2. Smoke chest
3. Expansion tank connection sleeve
4. Boiler return
5. Boiler outlet
6. Control panel (CP)
7. Door nuts
8. Handle
9. Flame observation port
10. Burner adapter flange
11. Boiler filling & discharge
12. Condensation water sleeve
13. Sanitary hot water connection sleeve

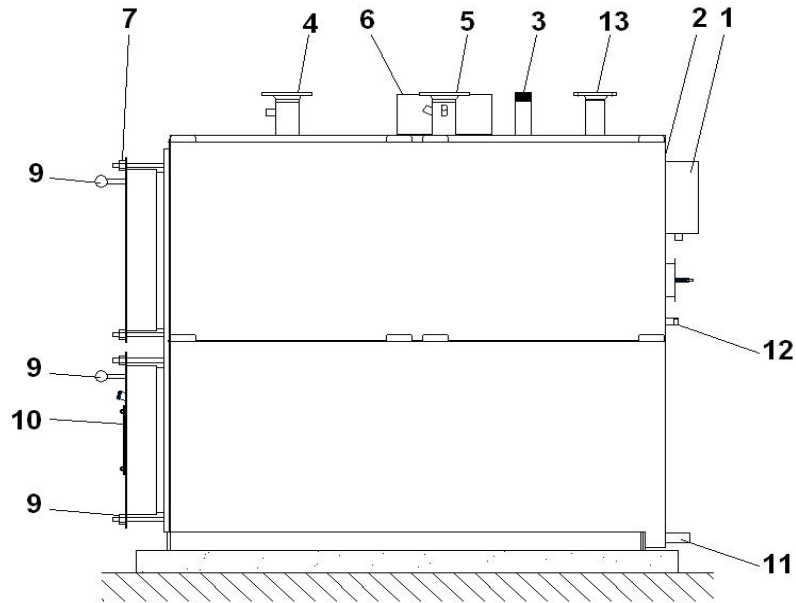

TR 465-1250

1. Chimney duct
2. Smoke chest
3. Expansion tank connection sleeve
4. Boiler return
5. Boiler outlet
6. Control panel (CP)
7. Door nuts
8. Handle
9. Flame observation port
10. Burner adapter flange
11. Boiler filling discharge
12. Condensation water sleeve
13. Sanitary hot water connection sleeve

BOILER DIMENSIONS

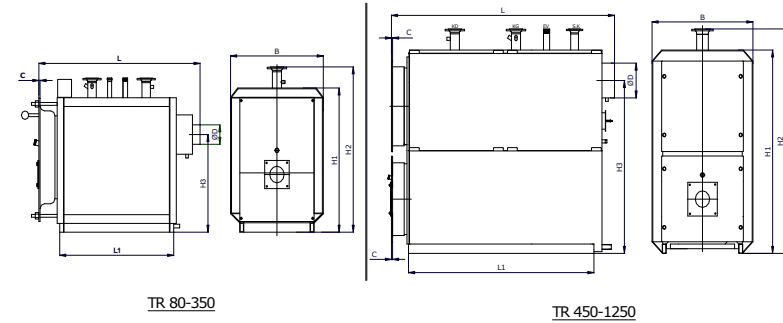

	BOILER CAPACITY											
	TR-80	TR-105	TR-150	TR-200	TR-250	TR-300	TR-350	TR-465	TR-600	TR-810	TR-1000	TR-1250
Capacity (kW)	80	105	150	200	250	300	350	450	600	800	1.000	1.250
Capacity (kcal/h)	68.800	90.300	129.000	172.000	215.000	258.000	301.000	387.000	516.000	688.000	860.000	1.075.000
Yield	93,9	94	94,3	94,6	94,8	95,2	95,4	95,4	95,4	95,4	95,4	95,2
L	1470	1466	1607	1790	1845	2095	2142	2202	2155	2618	2462	2662
L1	1100	1100	1200	1380	1420	1670	1720	1820	1820	2220	2020	2420
B	700	700	860	860	950	950	950	800	870	870	950	950
H1	1020	1020	1230	1230	1340	1340	1340	1658	1798	1798	1978	1983
H2	1225	1225	1435	1435	1545	1545	1545	1854	1999	1999	2187	2187
H3	718	718	893	893	948	948	948	1385	1555	1555	1690	1690
ØD	180	180	200	200	200	200	250	300	300	300	400	400
C	5	5	5	5	5	5	5	5	5	5	5	5
E	360	360	360	360	360	360	360	360	386	386	386	436
Empty weight (kg)	370	405	581	697	819	902	1008	1197	1453	1664	1950	2333
Outflow nozzle (BO)	DN50	DN50	DN50	DN65	DN65	DN65	DN65	DN80	DN80	DN100	DN100	DN125
Return nozzle (BR)	DN50	DN50	DN50	DN65	DN65	DN65	DN65	DN80	DN80	DN100	DN100	DN125
Expansion connection (SV)	DN32	DN32	DN40	DN40	DN40	DN40	DN50	DN50	DN50	DN65	DN65	DN80
Minimum thermal capacity (kW)	DN25	DN25	DN32	DN32	DN40	DN40	DN40	DN65	DN65	DN80	DN80	DN100
Water volume (lt)	220	230	400	460	520	620	620	550	580	690	790	930
Boiler connection nozzle (HT)	24	32	45	60	75	90	105	135	180	240	300	375
Counter pressure (m bar)	0,7	0,9	1,3	1,8	2,3	2,7	3	4,6	5,4	7,2	8,5	10,2

BOILER OPERATING PERSONNEL

Boiler operating personnel (boiler operator) should be knowledgeable about general boiler failures and their reparation, as well as the tasks and working principles of all measurement, adjustment, control and safety devices on the system.

The boiler operator should have an official document (boiler operator certificate) verifying his expertise on the abovementioned issues.



MAKE SURE THAT THE BOILER
PERSONNEL POSSESS BOILER OPERATOR
CERTIFICATE !

TRANSPORTATION AND TEMPORARY STORAGE:

- The boiler should be transported using the lifting and transportation points by detaching the top cladding sheet and appropriate equipment.
- For horizontal movement; where it is not possible to utilize a winch, horizontal displacement is possible through controlled sliding on pipes.
- The boiler should be protected against mechanical blows and collisions during loading, transportation and unloading.
- It must be protected against damages resulting from moisture and external mechanical factors that may arise during temporary storage before transportation and installation.



USE THE BOILER COMPLYING WITH
WARNINGS AND RECOMMENDATIONS IN
THIS PROCEDURE !

BOILER INSTALLATION

- Install the boiler in the boiler room at the installation site on a foundation elevated from the floor.
- Make the boiler mechanical connections as per the installation circuit diagram.
- Boiler installation site should comply with the related standards and procedures. It must have a door opening towards the outside, a fresh air inlet duct at floor level and a polluted air discharge chimney duct at ceiling level (apart from the boiler chimney). The door and the window frames must be of non-flammable material.
- The burner, the boiler control panel (if any) and the pre-heater connections should be performed by eligible technical personnel in compliance with the burner user manual and vendor installation diagram.
- The boiler must be used with the boiler control panel. (We also recommend a thermometer to be placed on the 1/2" sleeve located on the boiler return pipe.)
A hydrometer (open expansion) or manometer (closed expansion) should be placed on the boiler outlet pipe or collector.
- The boiler may be used in an open or closed expansion system. In case it is used in a closed expansion system; a closed expansion tank suitable for the total boiler and central heating water volume should be used at building static water level pressure and with adjusted gas side pressure. The closed expansion tank should be connected to the expansion nozzle directly on the boiler or to the boiler main outlet or return pipe provided that there is no stop gate valve. A pressure relief valve with opening pressure of 1,05 bars over the boiler operating pressure should be used.
- More than one boiler should not be connected to the same chimney.
- The boiler must be provided with a chimney and smoke channel in compliance with the regulations and standards of the authorized institutions regarding the fuel and smoke gas debit used.
- Our boiler has been designed for 90-70 C, stabilizing collector and secondary circulation pump must be used in the system for different temperature applications.
- The number 12 condensation water sleeve located in the figures of pages 7 and 8 must be plugged with the boiler room output by attaching a hose nipple and a hose to it.

In order to prevent battery corrosion, the boiler must be grounded with,

- a) 0.5m², 2mm thick copper sheet,
- b) 0.5m², 3mm thick hot dip galvanized sheet
- c) Massive copper bar electrodes.

EXPANSION TANK AND SAFETY PIPES

It is essential for the water not to be in direct contact with the air and the temperature not to rise above 100°C in open expansion hot water heating system. There should be outflow and return safety pipes between the boiler and the expansion container fully and independently, without any valves interrupting it in order to ensure the contact of water with the air and to ensure that this connection is not cut off by mistake or due to negligence. The safety valves should be installed without narrowing and continually rising towards the expansion tank.

Access to the outflow safety pipe and the expansion tank can be either from top or bottom. However the return safety pipe must be connected from the bottom. The diameters for both pipes based on tank capacity can be obtained from the table below. The safety pipes should never be smaller than 1".

Safety Pipe Diameters		
DIAMETER	Boiler capacity (kcal/h)	
	Outflow pipe	Return pipe
25 - 1"	50.000	100.000
32 - 1 1/4"	130.000	209.000
40 - 1 1/2"	280.000	630.000
50 - 2"	550.000	1.230.000
60 - 2 1/2"	900.000	2.000.000
70	1400.000	3.000.000
80	1900.000	4.200.000
90	2500.000	5.600.000
100	3200.000	7.200.000

Their diameters can be calculated by the following formula.

$$d_f = 15 + 1,5 * (Q_k / 1000)^{1/2} \quad [\text{mm}]$$

$$d_g = 15 + (Q_k / 1000)^{1/2} \quad [\text{mm}]$$

$$\text{Monitor} = 1/2"$$

It is strongly recommended to place a circulation connection and tap between the outflow safety pipe and expansion tank.

No hardware such as valve or check valve that clog the circulation should be placed on the safety valves.

The volume of the expansion tank is calculated based on the expansion as a result of the temperature rise of the water in the entire system from 10°C to t_m °C. The expansion tank volume in systems with normal hot water of 90/70 °C

$$\text{can be taken as } V_i = 0,06 * V_s \quad (\text{liter})$$

(V_s , is the total water amount in the system in liters)

$$V_s = W * Q_k \text{ (liter)}$$

Q_k = Boiler heating power (kW)

W = Specific water amount;

When convector is used : 5.20 lt/kW

When panel radiator is used : 8.33 lt/kW

When cast radiator is used : 12.00 lt/kW

With heating from flooring : 18.50 lt/kw

are the values.

The empirical volume of the expansion tank can be calculated roughly as follows.

$$V_i = 0.002 * Q_k \text{ (liter)}$$

Note: The volumes obtained are the useful volume of the tank, and the volume of the tank will be taken as 25% above than this volume.

The expansion tanks should conform to TS 713.

(DIN 4806 should be referred to for the matters that are not addressed by TS 713.)

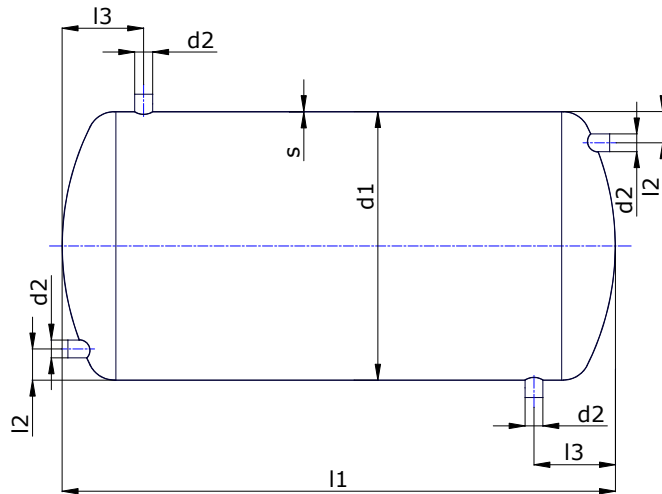

Volume (liters)	d1 (mm)	d2	l1 (mm)	l2 (mm)	l3 (mm)	S (mm)	Weight (kg)
30	300	R 1"	500	50	100	3	14
50	350	R 1"	580	50	105	3	19
75	400	R 1 1/4"	670	50	115	3	25
100	400	R 1 1/4"	870	60	115	3	31
125	500	R 1 1/4"	710	60	130	3	34
150	500	R 1 1/4"	850	60	130	3	40
200	500	R 1 1/2"	1110	60	140	3	49
250	500	R 1 1/2"	1350	60	140	3	57
300	600	R 1 1/2"	1180	60	150	3	63
400	650	R 2"	1310	70	170	3	77
500	700	R 2"	1420	70	180	3	89
600	700	R 2 1/2"	1660	80	190	3	103
800	800	R 2 1/2"	1700	80	200	4	158
1000	800	R 2 1/2"	2125	80	200	4	190

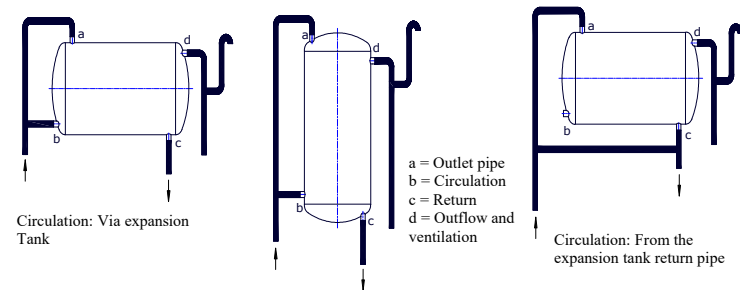
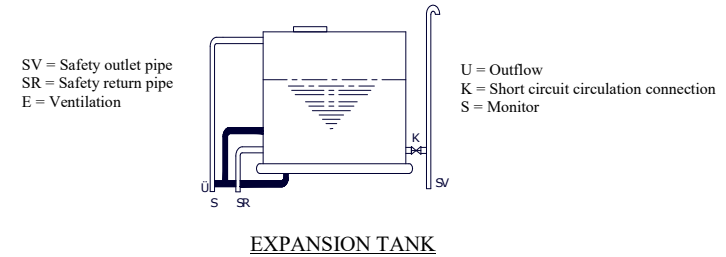

INSULATION CLADDING INSTALLATION

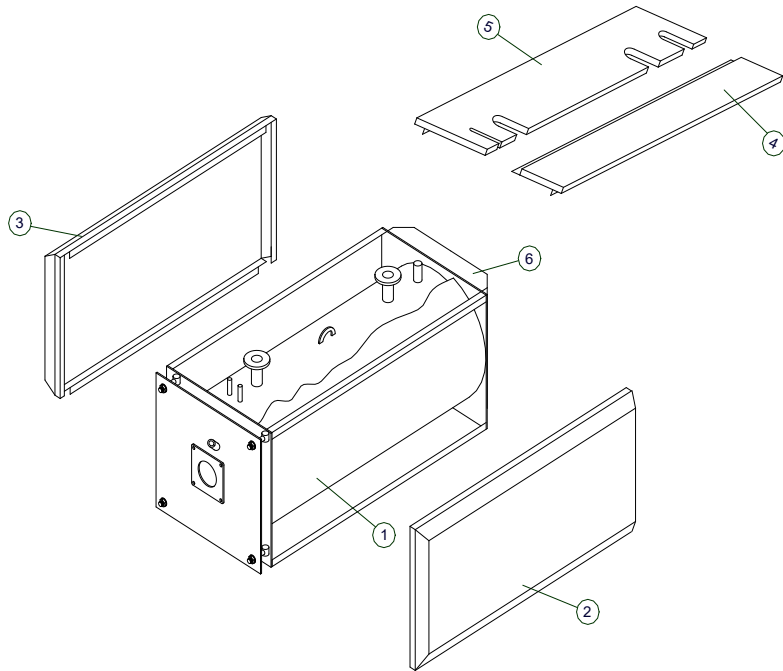

- Attach the side insulation claddings numbered 2 and 3 to the boiler. Make sure that they appropriately fitted into the slots on the skirts of the side cladding.
- Attach the No.4 upper insulation cladding onto the bottom slot and fit it in completely.
- Upon attaching the No.4 cladding, attach No.5 upper insulation cladding the same way.

BURNER SELECTION AND INSTALLATION

To achieve efficient combustion, the burner to be attached to the boiler should be selected in compliance with forming an appropriate flame for the combustion chamber defined in the boiler technical specifications section.

During the installation of the burner, care should be shown to match burner nozzle axis with combustion chamber axis.

To prevent entry of excess air into the combustion chamber from outside, the burner installation should performed carefully to prevent leakage.

The fuel used for operating should comply with burner manufacturer recommendations.

It should be calculate as; $\text{Burner firing power} = \text{Boiler capacity} / \text{Boiler efficiency}$. Choose an appropriate burner with this capacity that overcomes the boiler counter pressure. When ordering a boiler, inform the related sales personnel about the burner type selected, to ensure that the boiler door and connection flange is designed in compliance with the burner.

Use a burner with an appropriate head length in your boiler.

The burner head tip must enter the combustion chamber for a minimum of 30mm.

Burner operation and safety system must conform to the boiler control panel.

Our boiler can be used with single stage, double increment or double stage or modulating burner.

COMBUSTION CHAMBER DIMENSIONS

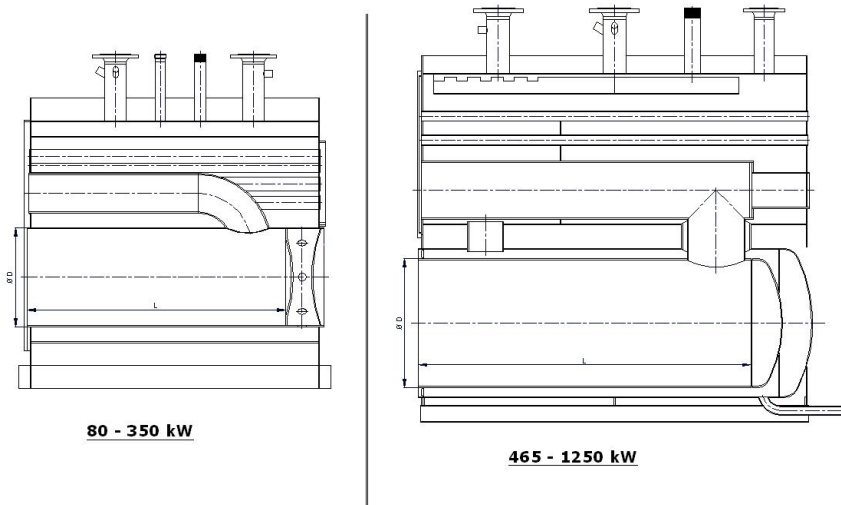

	BOILER CAPACITY											
	TR-80	TR-105	TR-150	TR-200	TR-250	TR-300	TR-350	TR-465	TR-600	TR-810	TR-1000	TR-1250
Combustion chamber length (L)	930	9330	1649	1229	1241	1491	1541	1680	1704	2104	1919	2370
Combustion chamber diameter (ØD)	350	350	450	450	550	550	550	552	604	604	704	704

FUEL SELECTION AND STORAGE:

- Fuel complying with the characteristics indicated in the burner user manual or burner vendor catalogues should be obtained.
- Fuel transfer lines should conform to current technical specifications, regulations and standards. The fuel tank-burner axis levels should not exceed figures specified in the burner user manual.
- Fuel tanks should conform to standards. A wall must exist between the fuel tank and the boiler.
- If fuel-oil is being used (especially of a heavier group), the necessary arrangements (RING LINE) and heating installation should be prepared for flow of fuel from the tank to the burner.



BEFORE OPENING THE FRONT DOOR,
SHUT OFF THE BURNER AND SHUT
DOWN BURNER ELECTRICITY !

FILLING THE SYSTEM WITH WATER

The boiler should be filled with water before operation. The boiler should not be operated before it is filled with water.

To fill the boiler with water, the main distribution and collection pipes, the boiler feeding pipes, installation column valves should be opened fully, water should be let in from the filling/discharge tap and it should be filled slowly until water starts coming from the monitor pipe of the Expansion Tank. In closed expansion systems, during water filling from boiler filling/discharge tap, the air discharge tube valves and mechanical purgers should be opened and then closed when it is observed that the incoming water does not have bubbles. When the air tube at the top most level of the installation or at the roof is completely filled with water, filling will be completed.

The circulation pump should not be operated during the filling process.
The expansion tank connections should conform to the installation circuit diagram.

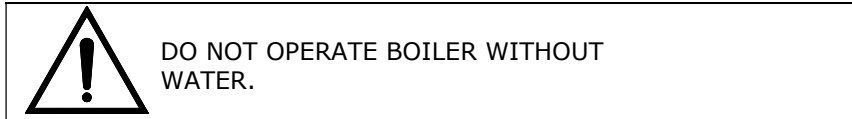

PREPARATION OF BOILER FOR OPERATION

The boiler room must be designed to meet the combustion air requirements of the boiler.

The boilers should be completely cleaned from internal and external dust, soot, etc.

The smoke channel, smoke pipe and chimney cleaning doors should be checked and leakages should be prevented.

The fuel heaters (when used with liquid fuel) and burner fuel connections should be checked for leakage. In gas fuel applications, the conformance of the provided pressure to the relevant burner and boiler, and if it has a seal, the functional operation of the control system should be checked.

The fuel filters should be cleaned, heater thermostats should be set to correct value, fuel valves should be set full and open.

The fuel combustion system should be reviewed with respect to the system's working principles and each element should be controlled for proper operation.

The boiler explosion door should be checked for proper operation.

Boiler safety devices (manometer, hydrometer, safety valve, visual and sound warning system etc.) should be reviewed to ensure proper operation.

SAFETY RULES

- Use the boiler only for hot water production for the closed-circuit heating system.
- Use the boiler complying with warnings and recommendations in this procedure.
- Have the heating system installed by authorized personnel.
- Have the boiler electrical connections made by authorized personnel.
- Do not operate boiler without water.
- When opening the front door and the front smoke chest door, shut off the burner and shut down burner electricity.
- Make sure the boiler personnel are certified boiler operators.
- Make sure that water conforming to EN 12953-10 is used in the boiler. (See page 41.)
- Boiler water temperature is designed for 90-70°C. Install a safety system to prevent water the temperature from exceeding 100°C.
- Perform the inspection and maintenance activities of the boiler thoroughly.
- The boiler chimney should be built in compliance with chimney building rules. Airbrick and briquette should not be used in boiler chimneys. The fuel used must conform to the standards and regulations in effect.
- The conformance of the chimney gas emission values to the national and international standards and regulations in effect must be ensured and checked.

- In closed expansion systems, the expansion tank gas pressure should be checked to be equal to that of the building static water height and the operation of the safety valve should be tested at opening pressure.
- Have the initial operation of the burner performed by authorized service of related burner company. The burner capacity adjustment should be made as per the label capacity of the boiler and the boiler efficiency value stated by the manufacturer firm for the boiler. A burner adjustment above the boiler capacity label value should not be allowed.
- If abnormal noises are heard from the boiler or the installation, the burner should be stopped immediately, and the fuel inlet should be closed. The investigation and repair of the malfunction should then be made.
- If leakages are observed on the burner fuel attachments and transfer lines, the burner should be immediately stopped, and line valves should be closed. If natural gas or LPG is used, use a leakage detector device in the boiler room and an automatic fuel cut-off system on the main inlet.
- If LPG is used, when icing and dew is observed on the fuel pipes due to the liquidizing of residual gas in fuel pipes from the previous night especially on cold days, the burner should absolutely not be used. The LPG should be carefully discharged from the drain tap. (Liquidizing may also form at normal times due to gasification level control or line regulator problem.)
- In cold climate regions, measures should be taken to prevent the installation water temperature from falling to freezing temperature. Circulation pump should be operated continuously at workplaces that are closed at night and during weekends. If heating is to be stopped for a long period of time, the boiler and system water should be discharged. Antifreeze should not be used. (Antifreeze causes corrosion and a decrease in water heating capacity.)
- If the burner malfunctions, burner computer reset button should not be pressed more than two times. If the burner still does not work, the related authorized service should be called.

PUTTING BOILER IN OPERATION

- Before the liquid/gas fuel heater boiler is operated, the existence of the following conditions should be controlled:
 - The liquid fuel in main fuel tank or the daily fuel tank should be heated to the required temperature turning on the heater circuit.
 - The valves on the liquid fuel circuit should not be opened fully.
 - Burner nozzle should be selected to suit burner and boiler capacity.
 - The pre-heater on the burner should be filled with liquid fuel and any air in it should be discharged.
 - The boiler thermostats should be adjusted to the suitable value.
 - It should be made sure that the heating system is filled with water.
 - The system should be filled with water and all the valves should be checked to be open. Air should be discharged from the air valves and purgers in the system. Circulation pump should not be operated during air discharge.
- Circulation pump should be started.
- The burner should be started from the switch on burner power panel.
- After the burner is running, nozzle pressure should be adjusted to burner and boiler power.
- When the boiler is in steady state (1-1.5 hours after the burner has started), burner air adjustment should be made using the chimney gas analysis device.
- In the case of gas fuel burner, fuel cut-off valves are opened, and the burner is started. In fuel-oil usage, the burner is started after the fuel is heated in the pre-heater tank.
- Hourly fuel consumption is calculated with the formula of $B = Qk / (Hu \cdot v)$.
B : Fuel quantity per hour [kg/h],[Nm³/h]

Q_k : Boiler output [kcal/h]
 H_u : Fuel lower heating value [kcal/kg],[kcal/Nm³]
 v : Boiler efficiency must be obtained from table on page 9.

- In liquid fuel applications, appropriate nozzle (45°), pump pressure (see burner catalog) should be selected.
- In gas fuel applications, the type of fuel (Natural gas, LPG) and gas consumption according to line pressure must be checked from the relevant gauge.
- If the boiler water is overheated, the circulation pump should be checked. (It may be turning in reverse due to misplaced connectors.) If that does not bring a solution, the burner should be stopped and the installation should be checked.
- Open the boiler door carefully.
- Protect the front door and the front smoke chest fire cement surface from collusion with hard objects (skewer, brush arm, turbulence makers, etc.).
- During the initial firing of the boiler after manufacturing, run it at a 25-30% capacity setting for about 2 hours to let the moisture in the cover fire cement be disposed.

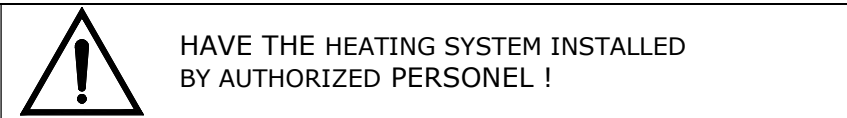

HEATING SYSTEM ADJUSTMENTS:

The boiler circulation pump should be checked for proper selection and adjustment.

a- Pump flow should be calculated with the formula below:

Q_p : Pump flow rate.

$Q_p = Q_k / [C_p * (t_g - t_d)]$: [lt/h].

Q_k : Boiler output [kcal/h]

C_p : Specific heat capacity of water [1 kcal/(kg.°C)]

ΔT is taken as $t_g - t_d = 20$ °C (in 90/70 °C system)

b- Pump pressure;

H_p : [mWC] Should be greater than the calculated critical circuit pressure loss of the building circuit.

The pump selection should be approved by the (Mech. Eng.) responsible for the building project and the technical application. Where a project and calculations do not exist or are not available, regulations can be made by placing thermometers, one each, on the boiler outflow and return lines, a manometer to the circulation pump exit and by adjustments with the help of the related pump curve, through the circulation pump valves so that the water temperature difference between outflow and return lines is 20°C. In the case of big pump selection, the outflow-return temperature difference will stay below 20°C and boiler outflow temperature may not rise, and in the case of small pump selection, the outflow return temperature difference will be over 20°C and the high and remote radiators may not function efficiently enough.

Every morning, the water level and pressure should be controlled from the hydrometer or manometer in the heating system. If it is below the normal value, water should be added while the boiler is cool. If it is a closed expansion system, the closed expansion tank gas pressure should be controlled to be equal to the static water height of the building. This control should be done on the expansion tank manometer if it is present, if not, it should be done from the gas side valve with a manometer.

If the pressure is excessive, it should be discharged from the related valve, if it is insufficient, nitrogen gas should be added by the expansion tank authorized service.

If water comes out from the valve during the check instead of gas or air, this means the tank diaphragm is torn and it should be changed by contacting an authorized service.

DISCHARGE OF BOILER WATER

- After a season's utilization, the boilers should be cleared of gasket remains, mud and residue in the heating system.
- The blind flanges at the lowest level of the main distribution and collection reservoir and boiler filling-discharge tap are opened, and the system and boiler water is rapidly flushed out.
- After cleaning the system should be filled with water (as described the article **filling the system with water**).
- The boiler water should not be discharged at any time except pre-operation cleaning and water should not be added to the boiler except for the purpose of compensating any depletion in the expansion tank.

TAKING BOILER OUT OF OPERATION

The taking of boiler out of operation should be as follows:

- The burner is stopped and boiler surfaces are cooled.
- The soot and smut in the boiler (the cover, smoke chest and the smoke pipes) should be cleaned.
- The cleaned surfaces should be checked under strong light to detect damages like leakages, oozing, cracks, etc. If such damages exist, the authorized services are notified and the necessary repairs are done.

- The liquid fuel between the burner and the main fuel tank should be discharged and the fuel system should be cleaned with kerosene.
- Active lime should be sprinkled into the combustion chamber, smoke pipes and smoke channels.
- The chimney cleaning flap should be brought to fully open position. It should be closed down after the chimney cleaning.
- The damaged heat insulators should be repaired.
- The burner maintenance should be done as per manufacturer recommendations.
- During non-operational period, the boiler room temperature should be kept at min. +5° C.
- The boiler and system water should not be discharged if it is not a necessity. Corrosion formation should be prevented. In long term idle states and at end of the heating season, appropriate chemical protective additive should be added to system water, to prevent negative effects of the oxygen in water on the metal surfaces.



PERFORM THE INSPECTION AND
MAINTENANCE ACTIVITIES OF THE
BOILER THOROUGHLY!

PREVENTION OF LOW TEMPERATURE CORROSION:

- The boiler pipes should not be allowed to burst due to low temperature corrosion formation. To prevent this:
- Liquid fuel with low sulphur content should be used.
- To prevent condensation of the gasses that pass from the boiler surfaces and the smoke pipes, boiler water outlet temperature should not drop below 60° C and smoke gas temperature below 70° C.
- 3-Way Valve or 4-way Valve should be used in the heating system.
- Soot and smut gathering on the heating surfaces (combustion chamber, smoke pipes, smoke chest) should not be allowed, cleaning process should be performed as frequently as possible.

- The burner should not be stopped and started frequently.
- Combustion should be controlled and ensured to be efficient. The burner settings should be done by the authorized service and if a re-setting is required, the related burner service should be contacted.

INSPECTION AND MAINTENANCE OF BOILER

1. General Maintenance

Heating system boilers should be subjected to general maintenance at least once a year. The following points should be checked during general maintenance.

- The operation of boiler armatures (thermostat, thermometer, hydrometer/manometer) should be observed continuously and in case of malfunction the required controls should be done and if needed, they should be changed. Heat transfer should be improved by filling the thermometer wells with thin lubricant.
- All connections in the system should be controlled for proper insulation, leakages and oozing should be repaired and if needed, the valve gaskets should be replaced.
- The boiler front big door and the front and rear smoke chest insulation elements should be checked continuously; if leakage exists, the tightening elements and nuts should be tightened in balance; if leakage is not stopped, gasket/sealant should be changed or our authorized services should be contacted. Grease the bolt screws and nuts of tightening elements.
- Perform the cleaning of the boiler combustion room, smoke pipes and smoke chest at least every 15 days in the case of liquid fuel usage, and at least every 60 days in the case of gas fuel usage. The turbulators should be taken out and all pipes should be cleaned with a suitable mop. Turbulators should be reinstalled in place after cleaning. For full boiler efficiency, all turbulators should be installed.
- At the end of season, the boiler should be cleaned fully, as in periodical cleaning. Boiler heating metallic surfaces should be protected against oxidation by applying transformer oil or a thin metallic lubricant.
- The boiler and system water should not be discharged if it is not a necessity. At end of season, appropriate chemical protective additive

should be added to system water, to prevent negative effects of the oxygen and similar corrosive elements in water on the metal surfaces.

- Temperature gages are compared to a calibrated thermometer.
- Safety elements, outlet and return safety pipes and safety valves are checked for proper operation.
- The mud and residuals at bottom of liquid fuel tanks are cleaned.
- The controls described in article on taking boiler out of operation, are performed.

2. Hydrostatic Test

Boiler parts such as the smoke pipe, nozzle, tube-sheet should pass a hydrostatic test under an authorized mechanical engineer's supervision, when replaced or every 5 years for control purposes.

For boilers under 1000kW (including 1000 Kw):

- Close all outlets and inlets with blind flanges except one outlet/return pipe left open.
- Let water into the boiler from the filling/discharge tap until water comes from the vent left open.
- Also plug the open vent with a blind flange.
- Pressure the boiler to 1.3 times the design pressure. Wait 20 minutes and then check for drop in pressure, leakage and permanent form changes.

For boilers over 1000kW:

The procedures described above are applied; test pressure is taken as 1.5 times the design pressure.

GENERAL BOILER MALFUNCTIONS

Malfunction Symptom	Reason	Solution
No firing	<ul style="list-style-type: none"> • Burner malfunction 	<ul style="list-style-type: none"> • Follow burner manufacturer recommendations.
Dark black smoke from chimney (in liquid fuel)	<ul style="list-style-type: none"> • Air excess coefficient is low • Circuit voltage low • Low fuel quality 	<ul style="list-style-type: none"> • Check the fresh air entering the boiler room or burner air setting. • Voltage drop will cause motor revolutions to drop and result with a low fuel-air mixture. • Get your fuel checked.
Drumming noise in boiler water compartment	<ul style="list-style-type: none"> • Air in system. • Wiring and installation error 	<ul style="list-style-type: none"> • Discharge the air. • Check the connections according to the system installation circuit diagram.
Overheating in boiler water	<ul style="list-style-type: none"> • Circulation pump malfunction. • Thermostat malfunction 	<ul style="list-style-type: none"> • Check circulation pump for reverse turning. • Check boiler thermometer for proper operation.

For malfunctions listed above, boiler operator personnel intervention is sufficient. For malfunctions apart from these, contact our authorized services.

Malfunction Symptom	Reason	Solution
Boiler output water temperature not rising	<ul style="list-style-type: none"> • High water speed • Burner selection and/or capacity not conforming 	<ul style="list-style-type: none"> • If the circulation pump is set for cycle, the cycle should be reduced, if it has one cycle the valve should be reduced and regulation should be conducted or should be replaced with an appropriate pump. • Get an authorized service to check your burner.
Water accumulation or leakage in smoke chest	<ul style="list-style-type: none"> • Water vapor condensation in smoke gas 	<ul style="list-style-type: none"> • The boiler should not be operated with low heat, the smoke gas at the boiler output should not be below 70°C, a valve with 3 or 4 ways should be used, the thermostat settings of the boiler should be high. The condensed water should be drained from the lowest level of the smoke chest via a connection.
Dye burn, heat rise, fire cement or turbulence maker deformation on the front door	<ul style="list-style-type: none"> • Incorrect burner selection and high setting 	<ul style="list-style-type: none"> • Burner replacement, repair to appropriate barrel measurement and burner adjustment are necessary. In liquid fuel, leakage and accumulation into the combustion chamber should be prevented.
Chimney gas temperature rising	<ul style="list-style-type: none"> • Operation without or with deficient turbulence maker, incorrect burner setting and selection 	<ul style="list-style-type: none"> • Turbulence maker should be attached or its deficiencies should be completed, the burner setting should be done correctly and appropriate burner should be provided



HAVE THE BOILER ELECTRICAL CONNECTIONS MADE BY AUTHORIZED PERSONEL !

BOILER CONTROL PANEL INSTALLATION INSTRUCTIONS

- Flax the 2 pieces of 1/2" brass cartridges supplied with the CP and install them on the sleeves on the outlet pipe of the boiler with proper insulation. Stop the empty sleeves with 1/2" blind plugs.
- Disassemble the CP body into two pieces, removing the 4 connection screws. Check that the marked 375x48 mm section at the base is drained. Pass the thermometer and thermostat sensors through this gap and place them (at most 3 each) in the cartridges. Put thin engine oil inside the casings and seal the upper part with silicon.

For TR 80 – TR 350 Types;

- Drill the CP lower body as below, from the screw points marked on 410 x 65mm axis measures with a 4mm tip, concurrently with the upper insulation sheet.

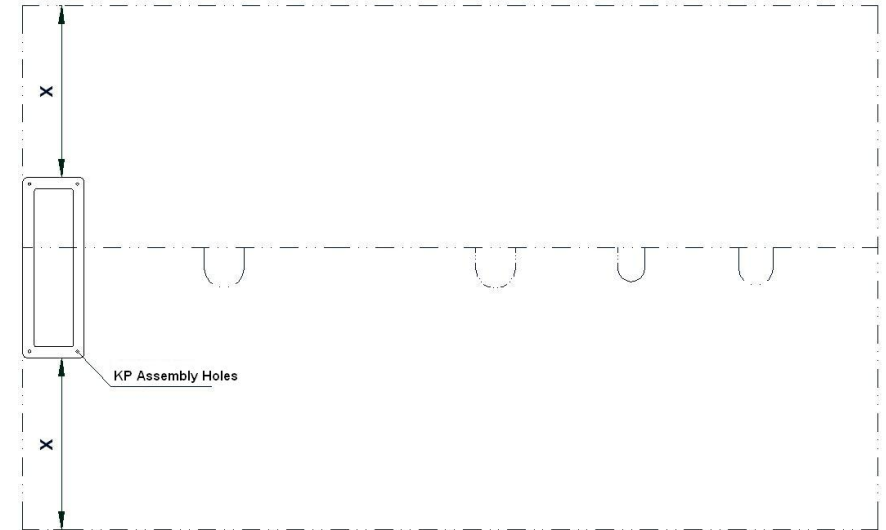

For TR 465 – TR 1250 Types;

- Drill the CP lower body as below, from the screw points marked on 410 x 65mm axis measures with a 4mm tip, concurrently with the upper insulation sheet.

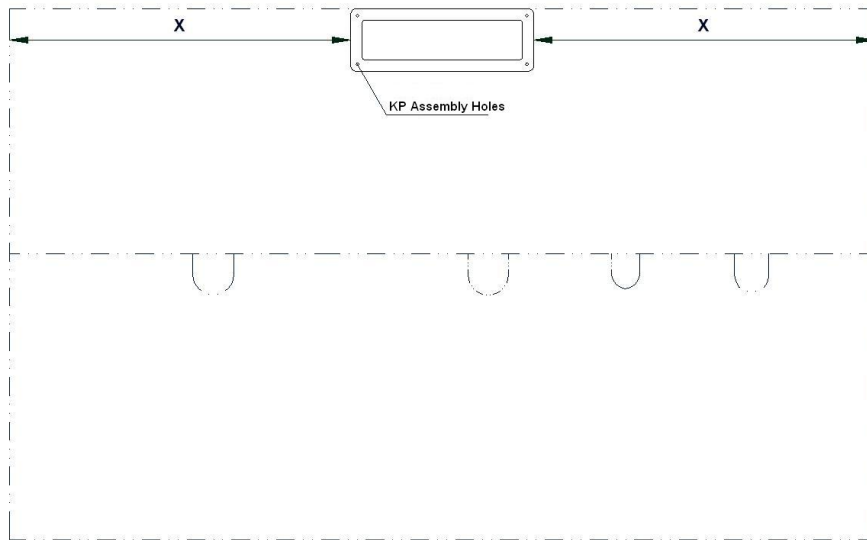

- Make the electrical connection between the CP exit contact and burner contact, complying with the wiring diagram (with the number of connections) with 0.75mm² cable. Open enough positions in the cross sectional area behind the CP for cable pass-through and use bushings.
- Securely screw the CP lower body onto the upper isolator sheet of the boiler with 4 4.2x13mm metal sheet screws.
- Put the upper body of the CP in place and close it by tightening with 4 screws.
- Ask the operating personnel to fill the boiler and system with water. When the boiler and system is filled with water, expansion system is

controlled, the circulation pump is seen to be operational, you may power the control panel.

- Make the sequential controls on the CP and declare that the burner may be started by the authorized service technician. Supervise the operation of the burner by the related technician and make the functional controls of the CP elements.
- When no adverse situations arise as a result of the functional controls and CP elements are observed to perform their tasks, you can set the CP operational.
- For problems and complaints related to the CP contact the nearest **erensan**^o Authorized Service.

CONTROL PANEL DIMENSIONS
Control panel external dimensions

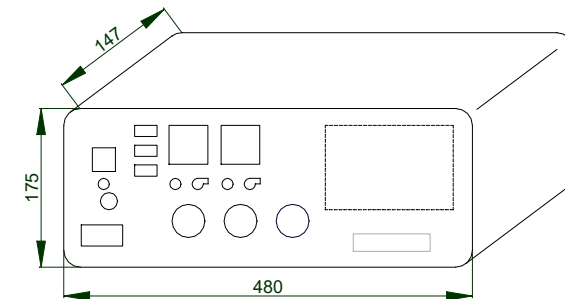

Control panel lower base installation dimensions

SHEET SCREW MOUNTING LOCATION (4.2x13mm)

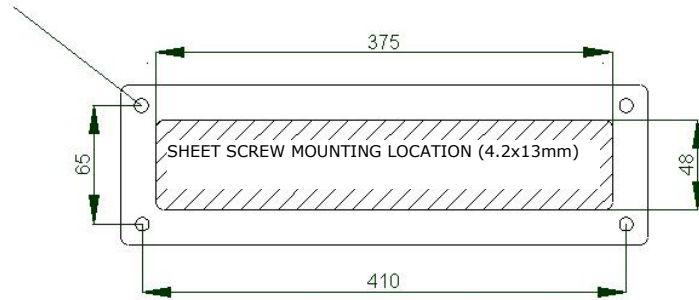

BOILER CONTROL PANEL ELECTRICAL SCHEMA KP-1 control panel

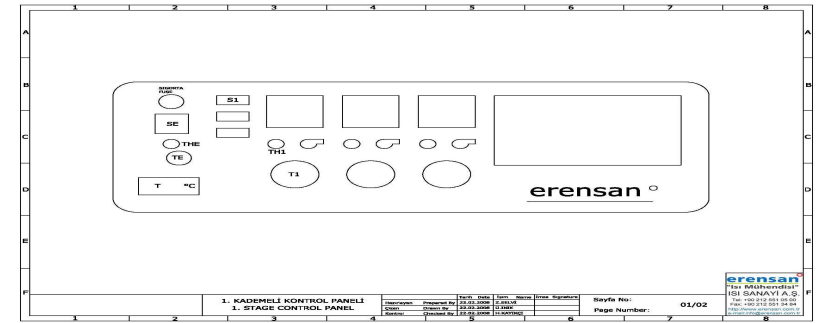

1. Manual on - off switch
2. Fuse (6A)
3. Safety thermostat (With manual reset)
4. Boiler water thermometer
5. Burner ON-OFF switch (1. Level)
6. Thermostat in service signal
7. Thermostat Limit

KP-1 ELECTRICAL SCHEMA

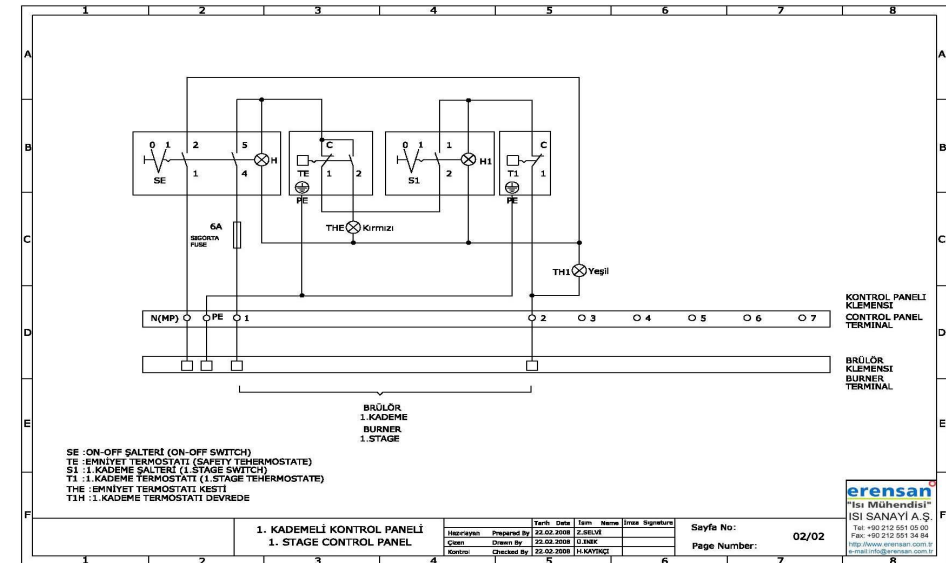

KP-2 control panel

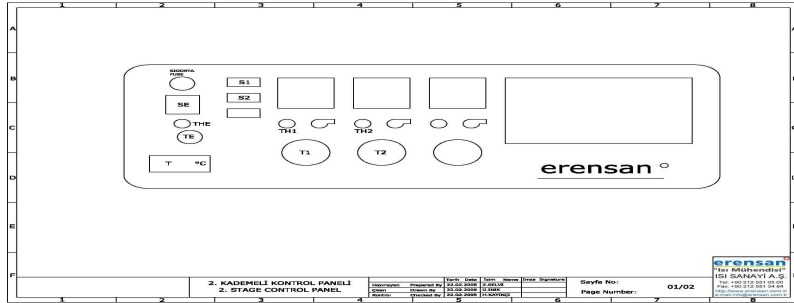

1. Manual on - off switch
2. Fuse (6A)
3. Safety thermostat (With manual reset)
4. Boiler water thermometer
5. Burner ON-OFF switch (1. Level)
6. Burner ON-OFF switch (2. Level)
7. 1st Level in service signal
8. I. Level thermostat
9. 2nd Level in service signal
10. II. Level thermostat

KP-2 ELECTRICAL SCHEMA

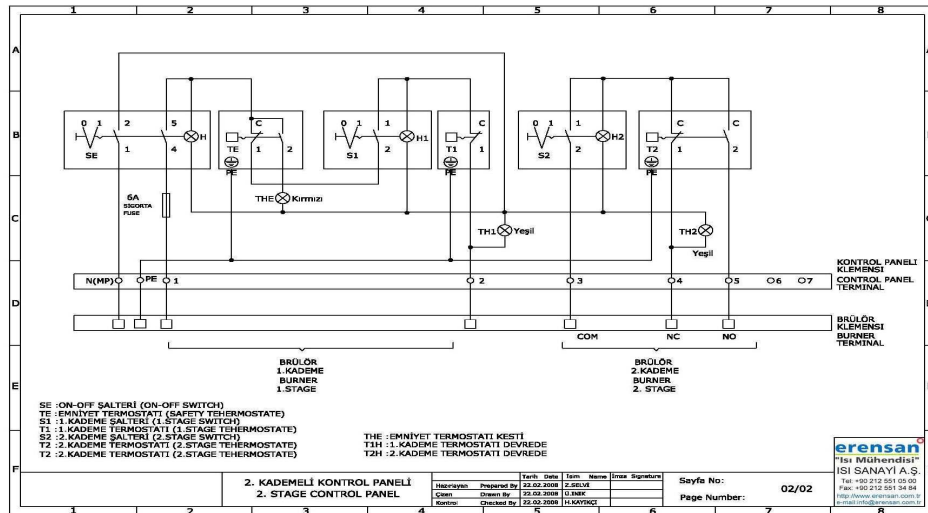

INSTALLATION CIRCUIT DIAGRAM (EXAMPLE) TR 80 - 350

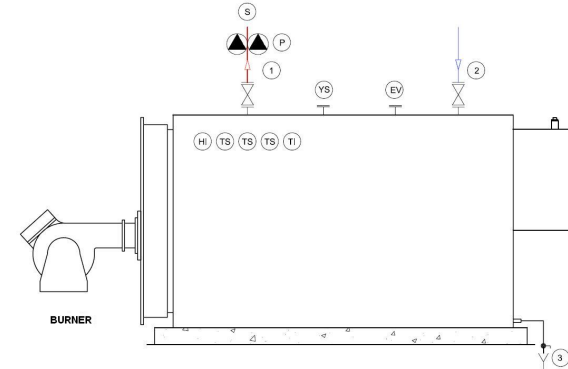

TR 465-1250

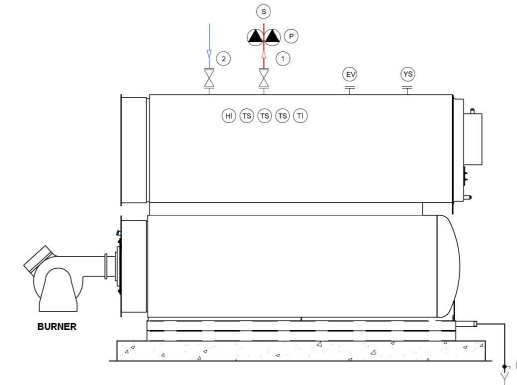

- HI Hydrometer
TS Thermostat 30-90 °C
TI Thermometer 0-120 °C
EV Expansion tank connection sleeve
YS Sanitary hot water connection sleeve
P Pump
S Supplying to the system
1. Supplying to the installation
2. Returning from the installation
3. Drain valve

BOILER FEED WATER AND BOILER WATER CHEMICAL CHARACTERISTICS

The water to be used in Hot Water boilers should conform to the table values indicated below.

The boiler feed water and boiler water should be checked constantly and the chemical conditions required for the water should be ensured in order to operated the boiler efficiently and economically.

FEEDWATER FOR HOT WATER BOILERS

Parameter	Unit	Make-up wa
		superhea
Operating Pressure	bar MPa	t t
Appearance	-	clear, free fr
Conductivity at 25 °C	µS/cm	
pH value at 25 °C ¹⁾	-	
Total hardness (Ca + Mg)	mg/liter(ppm)	< 5
Iron (Fe)	mg/liter(ppm)	
Copper (Cu)	mg/liter(ppm)	
Silica (SiO ₂)	mg/liter(ppm)	
Oxygen (O ₂)	mg/liter(ppm)	
Oil/grease	mg/liter(ppm)	
Organic substances	-	Se

¹⁾ With copper alloys in the system the pH value shall be maintained in the range 8,7 to 9,2

²⁾

³⁾

⁴⁾ If non-ferrous materials are present in the system, e.g. Aluminium, they may

require lower pH value and conductivity, however, the protection of the boiler has priority

BOILERWATER FOR HOT WATER BOILERS

Parameter	Unit	Boiler water for hot water & superheated water boilers
Operating Pressure	bar	total range
	MPa	total range
Appearance	-	clear, no stable foam
Conductivity at 25 °C	µS/cm	< 1500
pH value at 25 °C	-	9,0 to 11,5 ⁴⁾
Acid Capacity up to pH 8,2	mmol/liter	< 5
Silica (SiO ₂)	mg/liter	-
Phosphate (PO ₄) ⁵⁾	mg/liter	-
Organic substances	-	-
1)		
2)		
3)		
4) If non-ferrous materials are present in the system, e.g. Aluminium, they may require lower pH value and conductivity, however, the protection of the boiler has priority.		
5) If Phosphate is used; considering all other values higher PO ₄ -concentrations are acceptable, for instance with balanced or coordinated phosphate treatment (see also clause 4).		

Ref : prEN 12953-10, Table 5-1, 5-2; 1998

BOILER LIFE SPAN

The Ministry of Trade and Trade has determined the life span of hot water boilers as 10 years. If **erensan^o** brand boilers are utilized in compliance with operating and maintenance instructions, it is possible to go well over the ministry stated life span. Therefore, **make sure that this operating and maintenance procedure is read and fully applied by operating personnel.**

When the boiler has reached unusable state, remove the junk from usage area in compliance with environmental procedures.

erensan^o

a company of  GROUPE
ATLANTIC

ERENSAN ISI CİH. PAZ. VE SERVİS A.Ş.

Yassiören Mah. Balkırı Sk No:16-22

Arnavutköy -İSTANBUL

Phone: 0212 551 05 00 Fax: 0212 551 34 84

ERENSAN ISI CİH. PAZ. VE SERVİS A.Ş.

Öveçler Mah. 1314 sk. 41/B Çankaya-ANKARA

Phone: 0312 427 67 37 Fax: 0312 428 48 72

ERENSAN ISI TEKNİĞİ SAN. VE TİC. A.Ş.

Organize Sanayi Bölgesi, 107 Ada, 1-2-3 Parsel

66900 Yerköy-YOZGAT

Phone: 0354 558 11 20 Fax: 0354 558 11 23

<http://www.erensan.com.tr> e-mail: info@erensan.com.tr

İB52008-1

Our company reserves the right to make amendments without prior notification.