

# SSG H

## Liquid and Gas Fired Fuel, Water Tube, Package Steam Generator



- \* 500-2000 kg/h steam generation capacity
- \* 6-10 bar operating pressure
- \* Diesel oil and gas fueled
- \* Horizontal Type
- \* Can be used with pressure jet burner
- \* Up-to 91% boiler efficiency
- \* Reduced space requirement with compact design
- \* Very fast and uninterrupted steam generation with optimized heating surface
- \* Capability to locate under buildings in compliance with regulations
- \* Standard Equipment: Steam generator on the chassis, burner, condensation tank, feed water pump, pressure pump, operation and safety accessories, electric control panel water softening device

### SSG H

#### Diesel Oil and Gas Fueled, Water Piped, Package Steam Generator

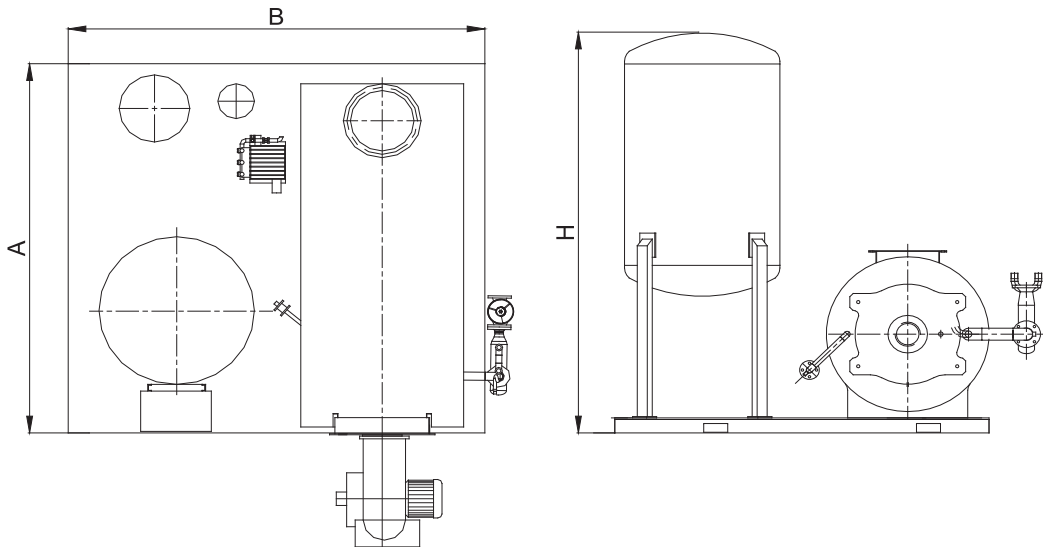

Technical Specifications	Unit	500	750	1000	1250	1500	2000
Steam Capacity	kg/h	500	750	1.000	1.250	1.500	2.000
Thermal Capacity	kW	327	491	655	818	982	1.309
Chassis Width (A)	mm	1.900	2.000	2.500	2.900	3.000	3.200
Chassis Depth (B)	mm	2.340	2.370	2.700	2.900	3.100	3.100
Height (Condensation Tank) (H2)	mm	1.983	1.970	2.052	2.622	2.644	2.626
Chimney Exit (Ø)	mm	250	300	350	400	450	450
Generator Water Volume	lt	39	90	127	171	194	296
Counter Pressure	mbar	3,5	4	5	6	7	8
Approximate Empty Weight	kg	1200	1575	1845	2048	2289	2865
Approximate Full Weight	kg	1650	2275	2775	3248	3689	4765